



Hugues-Salas, E., Wang, R., Kanellos, G. T., Nejabati, R., & Simeonidou, D. (2019). Co-existence of 9.6 Tb/s Classical Channels and a Quantum Key Distribution (QKD) Channel over a 7-core Multicore Optical Fibre. In *2018 IEEE British and Irish Conference on Optics and Photonics (BICOP)* (pp. 1-4). [8658328] Institute of Electrical and Electronics Engineers (IEEE).
<https://doi.org/10.1109/BICOP.2018.8658328>

Peer reviewed version

License (if available):
Other

Link to published version (if available):
[10.1109/BICOP.2018.8658328](https://doi.org/10.1109/BICOP.2018.8658328)

[Link to publication record in Explore Bristol Research](#)
PDF-document

This is the accepted author manuscript (AAM). The final published version (version of record) is available online via IEEE at <https://doi.org/10.1109/BICOP.2018.8658328> . Please refer to any applicable terms of use of the publisher.

University of Bristol - Explore Bristol Research

General rights

This document is made available in accordance with publisher policies. Please cite only the published version using the reference above. Full terms of use are available:
<http://www.bristol.ac.uk/red/research-policy/pure/user-guides/ebr-terms/>

Co-existence of 9.6 Tb/s Classical Channels and a Quantum Key Distribution (QKD) Channel over a 7-core Multicore Optical Fibre

Emilio Hugues-Salas
High Performance Networks (HPN)
School of Computer Science, Electrical
& Electronic Engineering and
Engineering Maths
University of Bristol
Bristol, UK
e.huguessalas@bristol.ac.uk

Rui Wang
High Performance Networks (HPN)
School of Computer Science, Electrical
& Electronic Engineering and
Engineering Maths
University of Bristol
Bristol, UK
rui.wang@bristol.ac.uk

George T. Kanellos
High Performance Networks (HPN)
School of Computer Science, Electrical
& Electronic Engineering and
Engineering Maths
University of Bristol
Bristol, UK
gt.kanellos@bristol.ac.uk

Reza Nejabati
High Performance Networks (HPN)
School of Computer Science, Electrical
& Electronic Engineering and
Engineering Maths
University of Bristol
Reza.Nejabati@bristol.ac.uk

Dimitra Simeonidou
High Performance Networks (HPN)
School of Computer Science, Electrical
& Electronic Engineering and
Engineering Maths
University of Bristol
Dimitra.Simeonidou@bristol.ac.uk

Abstract—This paper presents a record-high co-existence DP-16QAM coherent transmission of 9.6Tb/s for classical channels with one discrete-variable quantum key distribution channel over a 7-core Multicore fibre. We demonstrate that effective secret key generation is possible even with the combined crosstalk effect of the six adjacent cores over the quantum channel. Additional measurements show the impact on the secret key rate and QBER by adding coherent optical channels in different cores.

Keywords—quantum key distribution, multicore fibre, spatial division multiplexing, quantum co-existence

I. INTRODUCTION

Quantum Key Distribution (QKD) has emerged as the technology to offer quantum-grade encryption and strengthen the communication security when exchanging information. QKD has been proven to be the information theoretical secure (ITS) encryption of data, as the security relies on the fundamental laws of quantum physics, and thus it provides security on the physical layer which is resilient against all advances in classical computation and any quantum attack. In that sense, QKD is expected to enhance protection against brute force attacks by powerful classical computers and protect against the threat of quantum computing that will render public key encryption useless. Significant progress over the last two decades allowed QKD to reach commercialization [1], relying mainly on the DV-QKD technology, while large deployments in Vienna, Tokyo, Cambridge, Columbus or China testbeds [2-6] have demonstrated end-to-end QKD functionality on point-to-point links.

However, though QKD seems a promising technology to strengthen network security, there are specific problems that constrain its practical application in real optical networks and are due to the inherent nature of the quantum properties

of light and how these are handled. Specifically, DV-QKD relies its application on exchange of single photons or in very weak optical pulses and thus it is vulnerable to excessive optical losses in the link or to excessive photon-induced noise falling in the quantum channel. Main noise sources include: i) Raman Scattering (RS) from classical sources, ii) the non-filtered photons from classical channels (Ch- C), iii) the “in-band” noise photons induced by nonlinearity, e.g., FWM, and iv) the spontaneous emission (ASE) photons from optical amplifiers. While sensitivity to optical losses limits the lengths of transmission links and extensive research is working towards extending the QKD reach [7], it is the sensitivity to noise that restricts from deploying it in conventional optical network infrastructure in a co-existing form together with classical optical channels. However, as ICT infrastructure will not change to accommodate quantum network functions, a viable solution to the co-existing challenge has to be met.

Several co-existing schemes have been proposed so far relying mainly on wavelength and space multiplexing. Specifically, the first co-existence experiment [8] employed wavelength multiplexing and proposed the use of o-Band for conventional channels (CC) and the use of C-band for the QKD channel (QC). Other state-of-the-art developments have demonstrated co-propagation of QKD with one 100 Gbps dense wavelength-division multiplexing (DWDM) data channel in 150 km ultra-low loss fiber at 5 dBm launch power [9] while in [10] data transmission at Tbps level was achieved at 11 dBm launch power. Another field trial of simultaneous QKD transmission and four 10 Gbps encrypted data channels was implemented over 26 km installed fiber at 10 dBm launch power [11]. However, as launching powers induce more noise and spectral proximity is prohibitive, WDM co-existence of CC and QC is a compromise between launching powers, bandwidths and targeted secret key rates (SKR) for the quantum channels.

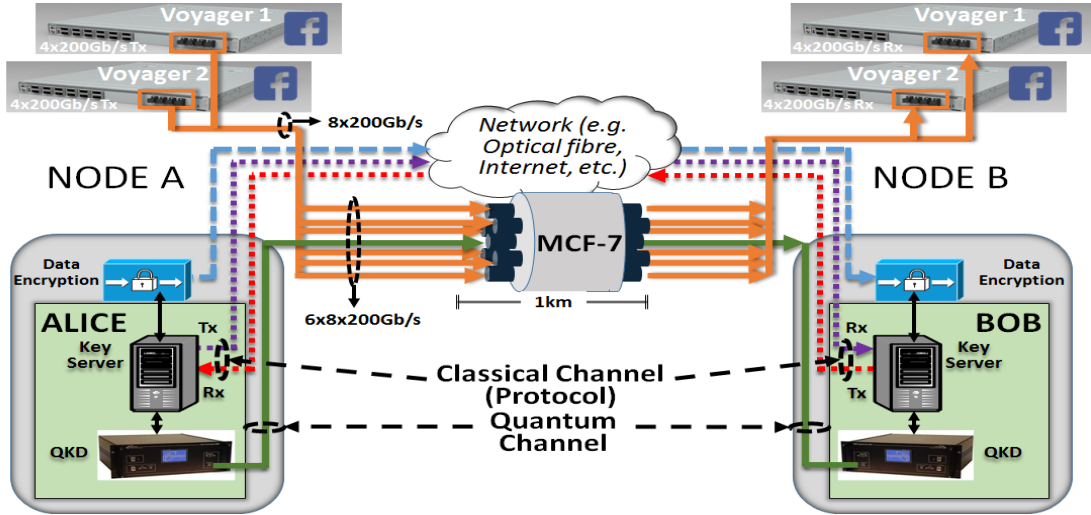

Fig. 1. Experimental setup for the co-existence of classical and QKD over Multicore Fibre

On the other hand, multi-core fibers (MCF) and space multiplexing offer enhanced channel isolation between cores and can in principle allow the unconditional co-existence of QC and CC [12]. In this direction, MCF have been exploited so far to optimize the SKR of the QC either by initiating the concept of high-dimensional quantum cryptography [13] or by exploiting the high intra-core crosstalk of MCF to demonstrate 605 kb/s SKR and 10 Gb/s classical channels [14]. However, none of the above experiments focused on optimizing the transmission versus the classical channels.

In the present communication, we employ a 1km long 7-core MCF fiber to demonstrate simultaneous transmission of a record high 10Tb/s classical channels distributed over 6 cores, while a 7th core is allowing the transmission of a DV-QKD channel.

II. QKD OVER MCF

A. QKD over MCF Experimental System Setup

Fig. 1 shows the experimental system setup of the co-existence between classical and quantum channels over a 7-core MCF. Table I includes the main parameters of the entire system. The system architecture consists of two nodes connected via a MCF medium. The QKD system employs commercially available ID Quantique systems (ID3100 Clavis2 [15]) that relies on DV-QKD. Alice unit is contained within Node A, consisting of a QKD transmitter unit and a key server (KS). Node A also includes the transmitted signals generated by two Facebook Voyager optical platforms [16] that each is powered with four 200Gb/s coherent transmitters from Acacia [17]. Each coherent signal emits in a different wavelength, and eight coherent signals are coupled together through a WDM multiplexer to form a 1.6Tb/s signal. In a similar way, Node B integrates a Bob receiver unit, a KS and the receiving part of the Voyager platform through the coherent receivers, after being demultiplexed. Data encryption and decryption can be undertaken with standard encryptors using the key generated by the quantum systems.

The two nodes are connected by a 1 km 7-MCF, with an average core pitch of $\sim 44.7 \mu\text{m}$ and a loss of 0.2 dB/km. One core of the MCF is used for QKD operating at 1551.70 nm (DWDM channel 32), while the other 6 cores are used for transmission of the multiplexed 8 coherent 200Gb/s channels.

B. MCF Crosstalk

Fig. 4 shows the measured crosstalk between all the cores throughout the 1 km MCF. Here a definition of the crosstalk is the ratio of the injected optical power on a selected core to the observed output power of another core. This approximation is undertaken to locate the core where the crosstalk is the lowest, thus enabling single photon exchange with the lowest residual noise impact. It is important to mention in here that the resultant measured crosstalk is the combination of the crosstalk observed in the MCF and the MCF fanouts. For this experiment, core 6 was selected for the QKD channel which has an average crosstalk of -51dBs from the other channels.

TABLE I. Multicore Fibre and QKD/Voyager Specifications

MCF Parameters	Value
Fibre Type	Step Index Core Multicore Fibre
Mode Field Diameter (MFD)	10.3 μm @1550nm
Propagation Loss	0.2dB/km @1550nm
Inter-core crosstalk	-48dB/1000m @1550nm
Core Pitch	44.7 μm (average)
Voyager Parameters	Value
Number of Coherent Ports/Voyager	4
Modulation Format	PM-16QAM
Capacity per wavelength channel	200Gb/s
Wavelengths	1540.580nm, 1541.408nm, 1542.193nm, 1542.978nm, 1546.945nm, 1547.752nm, 1548.537nm and 1549.343nm
Filter	0.3 roll-off factor root raised cosine
Channel Spacing (adjacent wavelengths)	100GHz
QKD Device Parameters	Value
Laser Wavelength	1551.7nm
QKD Protocol	BB84
Distance (Maximum)*	50Km@10dB of loss
Secret Key Rate#	> 500 bps over 25 km

*Maximum distance over standard single mode fibre (SSMF)

C. Experimental Results of QKD and 9.6Tb/s Classical Data over MCF

In Node A, the Alice QKD unit initiates the process of exchanging sequences of single photons with Bob's QKD unit over the dedicated core, to produce a secure shared key

which can be used to encrypt or decrypt information. Simultaneously, the Voyager's switches will transmit 200Gb/s of data per optical channel, with 16-QAM modulation (4 bits per symbol), for a total of 1.6 Tb/s for the eight channels used (Fig. 1). The combined data of 1.6Tb/s is splitted into six parallel optical fibres and transmitted over the remaining cores of the multicore fibre. Therefore, the total classical transmitted data over the MCF is 9.6Tb/s. The additional classical channel required used for exchange information of synchronisation and authentication for the quantum signals and to transform the photons exchanged via QKD into secure keys will communicate through an additional parallel link to the MCF. In real life, this optical link could undergo any conventional data path. A total link attenuation of 2.5dB is measured via the optical time domain reflexology method from the Alice QKD unit to the Bob QKD unit, passing through the MCF.

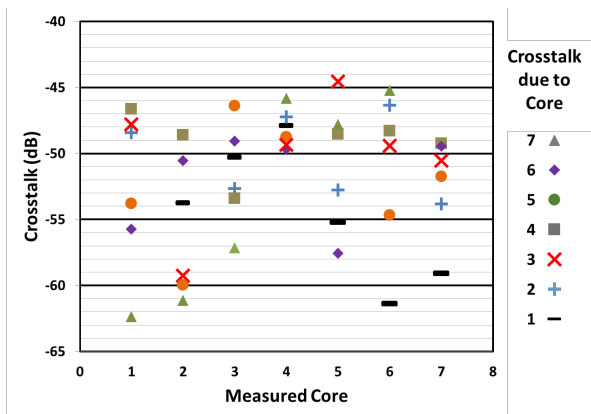

Fig. 2. Measured MCF Crosstalk @1551.7nm. (Measurement taken with OSA with dynamic range of >58 dB @0.4nm from peak wavelength and lowest optical sensitivity of -90 dBm).

Since the quantum channel is sensitive to crosstalk noise proliferation from other cores, additional filtering over the quantum channel in-band zone is added at the input ports of the MCF by using a Finisar Waveshaper with a selected bandwidth of 10nm, as shown in Figure 3. The peak power of each channel in each core after the MCF and before the receiver is shown in table II. The signal OSNR was 24.6dB leading to BER 5.6×10^{-4} , which is well beyond the 15% FEC error free reception limit.

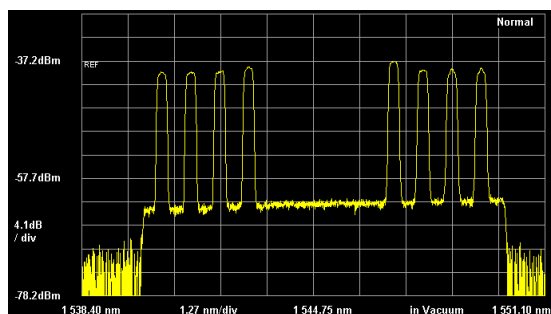

Fig. 3. Experimental setup for the co-existence of classical and QKD over Multicore Fibre

TABLE II. Optical Power in (Peak power per channel) at the receiver

Core Number	Power (dBm)
Core 1	-23.40
Core 2	-24.98
Core 3	-23.83
Core 4	-23.61

Core 5 -23.69
Core 6 -23.69

Fig. 3 shows the entire spectrum for the 9.6 Tb/s transmission. The selected channels from the Voyager platform were set in the wavelength range from 1540.580nm to 1549.34nm (Table I). Each channel is designed with a 50GHz bandwidth and the spacing between adjacent sets of 4 channels is 100GHz (0.8nm).

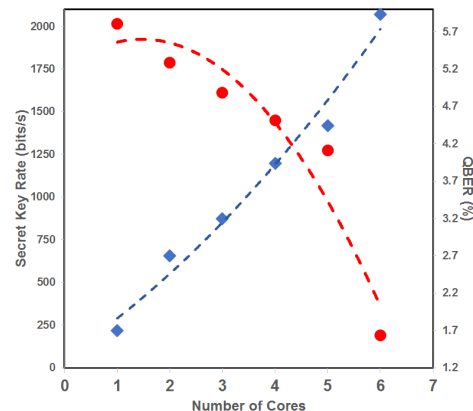

Fig. 4. Secret key rate and QBER after combined classical transmissions over the six cores remaining cores.

To understand the effect of the transmission of the classical data simultaneously to the QKD signal over the MCF, each core with 1.6 Tb/s signals was fed incrementally in the MCF. Fig. 4 shows the SKR and QBER measured after transmission over 1 to 6 cores in the MCF. It is clearly observed that the SKR decreases as the number of cores increases and that the QBER increases with more cores used for classical signal transmission, with a maximum SKR (QBER) of 2016b/s (1.7%), for only one core, and 191b/s (5.9%) for all the cores combined. However, it is demonstrated that the generation of keys with QKD is possible even with the crosstalk generated by all the six adjacent cores.

ACKNOWLEDGMENT

This work acknowledges the EU Horizon 2020 UNIQUORN, the project EPSRC EP/M013472/1: UK Quantum Hub for Quantum Communications Technologies and the EP/L020009/1: Towards Ultimate Convergence of All Networks. The authors also thank the support from Facebook for the Voyager switches in the experiment.

REFERENCES

- [1] <http://www.idquantique.com>
- [2] M Peev, et. al. "The SECOQC quantum key distribution network in Vienna", New Journal of Physics, Vol. 11, No. 075001, July 2009. pp. 1-37
- [3] M. Sasaki et al., "Field test of quantum key distribution in the Tokyo QKD Network", Opt. E pr., vol. 19, p.10387 (2011)
- [4] A. Wonfor et. al. "High performance field trials of QKD over a metropolitan network" QCRYPT 2017, Cambridge, UK, September, 2107, Th467
- [5] N. Walenta et al., "Towards a North American QKD Backbone with Certifiable Security", Proc. Qcrypt, 2015.
- [6] Y. Mao, et. al, "Integrating quantum key distribution with classical communications in backbone fiber network", Optics Express, Vol. 26, No. 5, Mar. 2018, pp. 6010-6020

- [7] A. Boaron, G. Boso, D. Rusca, C. Vulliez, C. Autebert, M. Caloz, M. Perrenoud, G. Gras, F. Bussières, M.-J. Li, D. Nolan, A. Martin, and H. Zbinden, "Secure quantum key distribution over 421 km of optical fiber", *Phys. Rev. Lett.* Vol. 121, No. 190502. Nov. 2018. pp. 1-4
- [8] I. Choi, R. J. Young, and P. D. Townsend, "Quantum key distribution on a 10 Gb/s WDM-PON," *Opt. Express* 18(9),9600–9612 (2010).
- [9] B. Fröhlich, M. Lucamarini, J. F. Dynes, L. C. Comandar, W. W.-S. Tam, A. Plews, A. W. Sharpe, Z. Yuan, and A. J. Shields, "Long-distance quantum key distribution secure against coherent attacks," *Optica* 4(1), 163–167 (2017).
- [10] L.-J. Wang, K.-H. Zou, W. Sun, Y. Mao, Y.-X. Zhu, H.-L. Yin, Q. Chen, Y. Zhao, F. Zhang, T.-Y. Chen, and J.-W. Pan, "Long-distance copropagation of quantum key distribution and terabit classical optical data channels," *Phys. Rev. A* 95(1), 012301 (2017).
- [11] I. Choi, Y. R. Zhou, J. F. Dynes, Z. Yuan, A. Klar, A. Sharpe, A. Plews, M. Lucamarini, C. Radig, J. Neubert, H. Griesser, M. Eiselt, C. Chunnillall, G. Lepert, A. Sinclair, J.-P. Elbers, A. Lord, and A. Shields, "Field trial of a quantum secured 10 Gb/s DWDM transmission system over a single installed fiber," *Opt. Express* 22(19),23121–23128 (2014).
- [12] R. Lin, A. Udalcovs, O. Ozolins, X. Pang, L. Gan, L. Shen, M. Tang, S. Fu, S. Popov, C. Yang, W. Tong, D. Liu, T. Ferreira da Silva, G. B. Xavier, and J. Chen, "Telecom Compatibility Validation of Quantum Key Distribution Co-existing with 112 Gbps/core Data Transmission in Non-Trench and Trench-Assisted Multicore Fibers", *European Conference on Optical Communications (ECOC'18)*, Rome, Italy, Sep. 2018.
- [13] G. Cañas, N. Vera, J. Cariñe, P. González, J. Cardenas, P. W. R. Connolly, A. Przysieszna, E. S. Gómez, M. Figueroa, G. Vallone, P. Villorosi, T. Ferreira da Silva, G. B. Xavier, and G. Lima, "High-dimensional decoy-state quantum key distribution over multicore telecommunication fibers", *PHYSICAL REVIEW A* 96, 022317 (2017).
- [14] J. F. Dynes, S. J. Kindness, S. W.-B. Tam, A. Plews, A. W. Sharpe, M. Lucamarini, B. Fröhlich, Z. L. Yuan, R. V. Pentyl and A. J. Shields, "Quantum key distribution over multicore fiber", in *Optics Express*. Vol. 24, No. 8, April, 2016. pp. 8081-8087
- [15] "ID Quantique Clavis2 QKD platform" [Online]. Available: <https://www.idquantique.com/resource-library/quantum-key-distribution/>
- [16] "Facebook Voyager Optical Platform" [Online] <https://code.fb.com/connectivity/an-open-approach-for-switching-routing-and-transport/>
- [17] "Acacia Transponders" [Online] <https://acacia-inc.com/product/ac400-flex/>