



**This electronic thesis or dissertation has been downloaded from the University of Bristol Research Portal, <http://research-information.bristol.ac.uk>**

*Author:*  
**Rogers, Molly E**

*Title:*  
**Aerial electroreception in *Bombus terrestris***

*examination of spatial resolution and exploration of implications for functionality and evolution.*

**General rights**

Access to the thesis is subject to the Creative Commons Attribution - NonCommercial-No Derivatives 4.0 International Public License. A copy of this may be found at <https://creativecommons.org/licenses/by-nc-nd/4.0/legalcode>. This license sets out your rights and the restrictions that apply to your access to the thesis so it is important you read this before proceeding.

**Take down policy**

Some pages of this thesis may have been removed for copyright restrictions prior to having it been deposited on the University of Bristol Research Portal. However, if you have discovered material within the thesis that you consider to be unlawful e.g. breaches of copyright (either yours or that of a third party) or any other law, including but not limited to those relating to patent, trademark, confidentiality, data protection, obscenity, defamation, libel, then please contact [collections-metadata@bristol.ac.uk](mailto:collections-metadata@bristol.ac.uk) and include the following information in your message:

- Your contact details
- Bibliographic details for the item, including a URL
- An outline nature of the complaint

Your claim will be investigated and, where appropriate, the item in question will be removed from public view as soon as possible.



**This electronic thesis or dissertation has been downloaded from Explore Bristol Research, <http://research-information.bristol.ac.uk>**

*Author:*  
**Rogers, Molly E**

*Title:*  
**Aerial electroreception in *Bombus terrestris*: examination of spatial resolution and exploration of implications for functionality and evolution.**

**General rights**

Access to the thesis is subject to the Creative Commons Attribution - NonCommercial-No Derivatives 4.0 International Public License. A copy of this may be found at <https://creativecommons.org/licenses/by-nc-nd/4.0/legalcode>. This license sets out your rights and the restrictions that apply to your access to the thesis so it is important you read this before proceeding.

**Take down policy**

Some pages of this thesis may have been removed for copyright restrictions prior to having it been deposited in Explore Bristol Research. However, if you have discovered material within the thesis that you consider to be unlawful e.g. breaches of copyright (either yours or that of a third party) or any other law, including but not limited to those relating to patent, trademark, confidentiality, data protection, obscenity, defamation, libel, then please contact [collections-metadata@bristol.ac.uk](mailto:collections-metadata@bristol.ac.uk) and include the following information in your message:

- Your contact details
- Bibliographic details for the item, including a URL
- An outline nature of the complaint

Your claim will be investigated and, where appropriate, the item in question will be removed from public view as soon as possible.

**Aerial electroreception in *Bombus terrestris*:  
examination of spatial resolution and  
exploration of implications for functionality  
and evolution.**

Molly Rogers

A dissertation submitted to the University of Bristol in accordance with the requirements for the award of the degree of MSc in the Faculty of Life Sciences, School of Biological Sciences.

July 2020

Word Count: 20408

# Abstract

*Bombus terrestris*, the buff-tailed bumblebee, is widespread across the UK and Europe. This species has been extensively studied as a model organism, and much is known about its natural history and behavioural ecology. *B. terrestris* is known to be a generalist forager and to rely on sensory information to locate food sources.

This bee has recently been shown to be receptive to electric fields, and to be able to learn and discriminate between different electric field geometries. While a putative mechanism of electroreception has been suggested, there are still many questions to be answered regarding the function of electroreception in the behaviour and ecology of *B. terrestris*, and how electrical information is processed by the bee.

This study examines the electric sense in *B. terrestris*, aiming to clarify the potential ways this sense may impact the way the bee experiences the world and how, in turn, this will affect its behaviour. The study focusses on elucidating the spatial resolution of the sense, providing suggestions for a procedure to use in future work, and speculates about the ways in which this information may aid in understanding electroreception further.

# Acknowledgments

I would like to thank everyone who has helped me in the production of this thesis.

Firstly, I would like to thank my supervisor, Professor Daniel Robert, for his ideas and support, and for believing in me when I didn't believe in myself. I would also like to thank Clara Montgomery and Erica Morley for their suggestions, help and encouragement, along with all other members of the biophysical research group.

Within the University of Bristol, I would like to thank Emily Bell for her support and encouragement, especially when I was struggling with my health and my spirit, and Richard Wall for his helpful advice and suggestions.

I would also like to thank my mentor, Alison Farnworth-Cole for keeping me on track and helping me develop personally over the past two and a half years.

I would like to thank my friends and family. In particular, my housemates who kept me sane when I was working too hard, and my dad and sister who never stop supporting me.

Finally, I would like to thank my mum for her constant and unwavering support, and my partner Jacob for looking after me and making me happy.

# Author's Declaration

I declare that the work in this dissertation was carried out in accordance with the Regulations of the University of Bristol. The work is original except where indicated by special reference in the text and no part of the dissertation has been submitted for any other degree.

Any views expressed in the dissertation are those of the author and in no way represent those of the University of Bristol.

The dissertation has not been presented to any other University for examination either in the United Kingdom or overseas.

SIGNED..........

DATED: 24/07/2020

# Table of Contents

Abstract .....	ii
Acknowledgments.....	iii
Author’s Declaration .....	iv
Table of Contents .....	v
List of Figures.....	vii
List of Tables .....	viii
Chapter 1: Introduction to electroreception.....	1
1.1 – Introduction.....	2
1.2 – Electroreception in vertebrates.....	2
1.3 – Electroreception in aquatic invertebrates.....	5
1.4 – Aerial electroreception.....	6
1.4.1 – Electric ecology .....	6
1.4.2 – Electroreception in <i>Bombus terrestris</i> .....	7
1.4.3 – Other species .....	9
1.5 – Electrostatics and pollen transfer .....	10
1.5.1 – Buzz Pollination .....	11
1.6 – Conclusion .....	12
Chapter 2: The natural history and sensory ecology of <i>Bombus terrestris</i> .....	13
2.1 – Introduction.....	14
2.2 – Ecology and Natural History .....	14
2.3 – Sensory Ecology .....	15
2.3.1 – Vision .....	16
2.3.2 – Chemosensory perception.....	20
2.3.3 – Vibrational sensing.....	22
2.3.4 – Fluid flow sensing.....	24
2.4 – Floral cues.....	24
2.5 – Conclusion .....	25
Chapter 3: Methodology .....	26
3.1 – Introduction.....	27
3.2 – Experimental design.....	27
3.2.1 – Bees .....	27
3.2.2 – Harness design.....	27

3.2.3 – Habituation-dishabituation paradigm.....	29
3.2.3.1 – The habituation stimulus ( <i>h</i> ).....	31
3.2.3.2 – PER olfactory conditioning trials.....	31
3.2.3.3 – Results of PER trials.....	33
3.2.3.4 – Determining the habituation stimulus ( <i>h</i> ).....	33
3.3 – Exploring distance.....	35
3.4 – Exploring direction.....	36
3.5 – Conclusion.....	37
Chapter 4: Discussion.....	38
4.1 – Introduction.....	39
4.1.1 – Signals or cues?.....	39
4.2 – Function of aerial electroreception in <i>Bombus terrestris</i> .....	40
4.2.1 – Foraging.....	40
4.2.1.1 – Floral cues.....	40
4.2.1.2 – Nectar guides.....	44
4.2.1.3 – Indication of nectar availability.....	45
4.2.2 – Intraspecific communication.....	46
4.2.3 – Heterospecific communication.....	47
4.2.4 – Predator avoidance.....	48
4.3 – Application of the methodology.....	49
4.3.1 - Distance.....	49
4.3.2 – Direction.....	51
4.4 – Aerial electroreception in other arthropods.....	52
4.5 – Areas for further research.....	54
4.6 – Conclusion.....	55
References.....	56
Appendices.....	69
Appendix 1: Harness materials.....	69



# List of Figures

**Figure 1.1** – “Phylogeny of extant vertebrates, showing the evolution of electroreception and electrogenesis from electric organs (EO), with predominantly terrestrial taxa in bold.” Reprinted from “Electroreception, electrogenesis and electric signal evolution”, by W. G. R. Crampton, 2019, *Journal of Fish Biology*, 95(1), p. 95

**Figure 1.2** – The bills of the platypus (*Ornithorhynchus anatinus*), long-billed echidna (*Zaglossus bruijnii*) and short-billed echidna (*Tachyglossus aculeatus*) showing the number and location of electrosensory receptors. Reprinted from “Electroreception in monotremes”, by J. Pettigrew, 1999, *Journal of Experimental Biology*, 202(10), p. 1450.

**Figure 1.3** – Intracellular electrophysiological recordings of the antenna (A) and filiform hair (B) of a bumblebee, *Bombus terrestris*, in response to an electric-field stimulus. The filiform hair responds with an increased neural firing rate whereas the antenna shows no response to the stimulus. Adapted from “Mechanosensory hairs in bumblebees (*Bombus terrestris*) detect weak electric fields”, by G. Sutton, D. Clarke, E. Morley and D. Robert, 2016, *Proceedings of the National Academy of Sciences of the United States of America*, Volume 113(26), p. 7264.

**Figure 1.4** – Electrostatic forces between a charged acrylic rod and an earthed flower elicit bi-directional pollen transfer. Reprinted from “The bee, the flower, and the electric field: electric ecology and aerial electroreception”, by D. Clarke, E. Morley and D. Robert, 2017, *Journal of Comparative Physiology A*, Volume 203(9), p. 745.

**Figure 2.1** – The ratio of large to small *B. terrestris* workers recorded visiting eight plant species, plotted against corolla depths of the plants. Reprinted from “Does intraspecific size variation in bumblebees allow colonies to efficiently exploit different flowers?”, by J. Peat, J. Tucker and D. Goulson, 2005, *Ecological Entomology*, 30(2), p. 179.

**Figure 2.2** – Photographs of three flowers under visual (left) and UV (right) light conditions. Flowers shown are a) *Bidens ferulifolia*, b) *Rudbeckia fulgida*, and c) *Erodium manescavii*, all of which are pollinated by insects, including bumblebees. Reprinted from “Ultraviolet patterns of flowers revealed in polymer replica – caused by surface architecture”, by A. J. Schulte, M. Mail, L. A. Hahn and W. Barthlott, 2019, *Journal of Nanotechnology*, Volume 10, p. 461.

**Figure 2.3** – Volume rendering of the dried heads of a small (left) and large (right) *B. terrestris* worker from the same colony. Adapted from “Bumblebee visual allometry results in locally improved resolution and globally improved sensitivity”, by G. Taylor, P. Tichit, M. Schmidt, A. Bodey, C. Rau and E. Baird, 2019, *eLife*, 8, p. 4

**Figure 2.4** – Response of a charged *B. terrestris* filiform hair is of a comparable level to its response to acoustic stimuli. When played in anti-phase ( $\pi/2$ ), the motion of the hair almost ceases. Adapted from “Bumblebee hair motion in electric fields”, by K. Koh, C. Montgomery, D. Clarke, E. Morley and D. Robert, 2019, *Journal of Physics: Conference Series*, Volume 1322(1), p. 3.

**Figure 3.1** – Graph representing the habituation-dishabituation paradigm, showing the change in the strength of a behavioural response to a repeated stimulus before and after dishabituation.

**Figure 3.2** – Traditional restraint used in PER experiments. Reprinted from “Classical Conditioning of Proboscis Extension in Honeybees (*Apis mellifera*)”, by M. Bitterman, R. Menzel, A. Fietz and S. Schäfer, 1983, *Journal of Comparative Psychology*, 97(2), p. 108.

**Figure 3.3** – Diagrams of each of the harnesses used to restrain bees during experimentation. Further information about the designs and materials used can be found in Appendix 1.

**Figure 3.4** -Bar graph showing the percentage of successful PER trials for bees restrained in each of the eight harness designs.

**Figure 3.5** – Diagram of experimental setup. The bee is held within the sensory isolation box between two electrodes, one charged and one earthed. There is a camera within the wall of the box to allow real-time observations of the bees’ reactions to stimuli.

**Figure 3.6** – Percentage of bees that responded with antennal twitches (blue bars) and successfully habituated and dishabituated (orange bars), compared for tactile stimulation of the antenna and the thorax. There is no significant difference between either responses to the two treatments.

**Figure 3.7** – Proposed experimental setup to test directional electrosensing in *B. terrestris*.

**Figure 4.1** – “Visualisation of floral electric fields using electrostatic dusting. Flowers are shown before (left) and after (right) dusting... Genera shown are a) *Lilium*, b) *Gerbera* [and] c) *Narcissus*.” Adapted from “The bee, the flower, and the electric field: electric ecology and aerial electroreception”, by D. Clarke, E. Morley and D. Robert, 2017, *Journal of Comparative Physiology A*, 203(9), page 743.

**Figure 4.2** – Change in electric potential of a petunia stem over the course of visitation by a bumblebee, *Bombus terrestris*. Adapted from “Detection and Learning of Floral Electric Fields by Bumblebees”, by D. Clarke, H. Whitney, G. Sutton and D. Robert, 2013, *Science*, 340(6128), page 67.

**Figure 4.3** – *Misumena vatia*, a cryptic predator of bumblebees with its prey, a yellow-faced bumblebee (*Bombus vosnesenkii*). Printed with permission from Dean, N. (2015). *Bombus vosnesenkii* (Yellow-faced Bumble Bee) - *Misumena vatia* ♀ (Flower Crab Spider). [Photograph]. South Everett, USA. [www.flickr.com/photos/44691276@N06/18945175381/in/photostream/](http://www.flickr.com/photos/44691276@N06/18945175381/in/photostream/)

**Figure 4.4** – General structure of an insect antenna showing the three main segments: the scape, pedicel and flagellum. The Johnston’s Organ is within the pedicel. Adapted from Antenna [Electronic image]. (2015) Why And How Science. [www.whyhowscience.wordpress.com/2015/11/15/antenna/](http://www.whyhowscience.wordpress.com/2015/11/15/antenna/)

## List of Tables

**Table 3.1** – Schedule of training and testing of PER responses. The CS is a puff off air from a pipette containing filter paper soaked in lavender oil and the US is a reward of 30% sucrose solution.



# Chapter 1: Introduction to electroreception

## 1.1 – Introduction

The term electroreception first appeared in scientific literature in 1959 in a paper by Theodore Holmes Bullock (Bullock, 1959) referring to nerve impulses generated by sense receptors. Since then, the term has come to refer to the ability of an organism to sense electrical stimuli, a phenomenon first identified in the knifefish, *Gymnarchus niloticus*, which was found to respond to disturbances in its ambient electric field (Lissmann, 1951). For many centuries, humans have been aware of the ability of some fish such as electric eels (*Electrophorus electricus*) to produce electrical discharges, but until this point the ability to sense low frequency electric currents was unknown (Carlson & Sisneros, 2019).

The majority of research into electroreception to date focusses on marine and freshwater vertebrates, though there has been some exploration into the electroreceptive capabilities of other organisms including invertebrates, such as freshwater crayfish, and terrestrial vertebrates, such as the echidna. In this chapter I will present a review of the existing literature on electroreception, discussing the phylogenetic spread of electrosensing and the mechanisms, behavioural functions and adaptations of electroreception in different organisms. I will provide some details on sensory mechanisms and the ecological context, taking into account the medium by which electricity travels.

## 1.2 – Electroreception in vertebrates

There are two types of electrosensing used by vertebrates: passive and active. In the former, animals sense the low frequency DC electric fields produced by other organisms in their environment through sensory cells called ampullae (Collin, 2019). In active electrosensing, animals emit high frequency (50Hz - <2kHz) electrical pulses from Electric Organs (EOs) which contain excitable cells called electrocytes, thought to have evolved independently in six major groups of fishes (Crampton, 2019). Animals which produce these electrical signals (also known as Electric Organ Discharge, EOD) possess high frequency-tuned tuberous electroreceptors which detect changes in their EOD that in turn indicate the presence of nearby objects, in a similar way as other animals use echolocation (Collin, 2019).

Electroreception is a thought to have evolved a number of times in vertebrates (fig. 1.1; Crampton, 2019). Around 16% of extant fish species are capable of passive electroreception whereas only an estimated 1.5% of species possess electric organs and are therefore capable for active electroreception (Crampton, 2019).

Alongside fish, a small number of mammal species have also been reported to use passive electroreception. The Guiana dolphin (*Sotalia guianensis*) is thought to use this sense to supplement echolocation when detecting prey in low-visibility conditions (Czech-Damal et al., 2013). The electroreceptors of this species, which take the form of vibrissal crypts on the upper jaw containing a

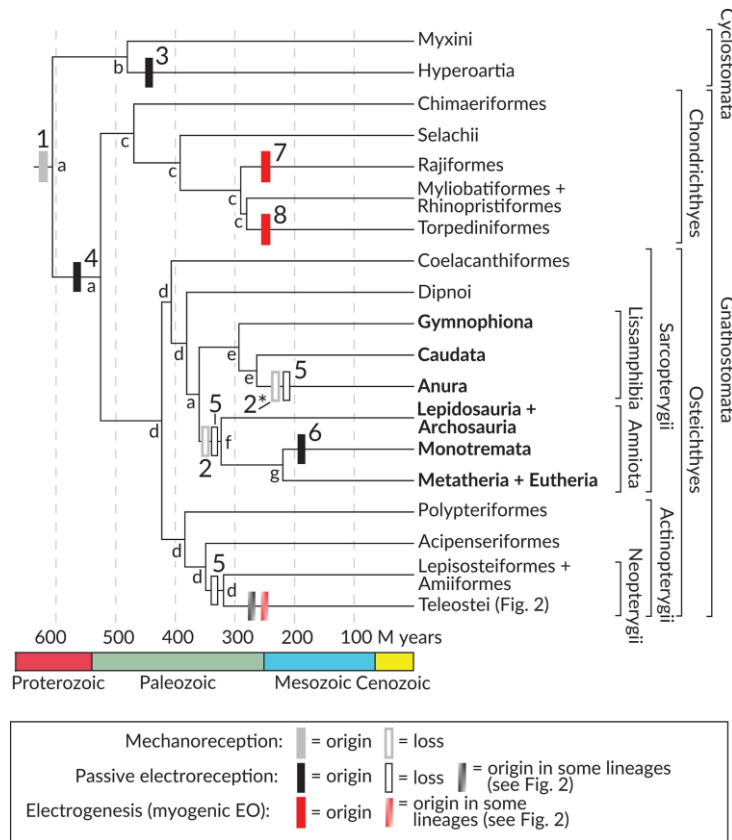

Figure 1.5 – “Phylogeny of extant vertebrates, showing the evolution of electroreception and electrogenesis from electric organs (EO), with predominantly terrestrial taxa in bold.” Reprinted from “Electroreception, electrogenesis and electric signal evolution”, by W. G. R. Crampton, 2019, *Journal of Fish Biology*, 95(1), p. 95

highly conductive glycoprotein-based gel, are similar in morphology to the ampullary receptors of fishes (Czech-Damal et al., 2013).

Other mammals capable of electroreception include monotremes, all extant species of which possess some degree of electroreceptive ability (Pettigrew, 1999). The platypus (*Ornithorhynchus anatinus*) is a semiaquatic monotreme which feeds on benthic freshwater invertebrates. When hunting, the platypus can determine the exact location of its prey while its eyes, ears and nose are tightly closed. To do this it uses its ‘bill sense’ which consists of a combination of electro- and mechanosensors located in its bill (Pettigrew, 1999).

The other species of monotremes, the echidnas (family: *Tachyglossidae*), also use electroreceptors located in the snout to sense the movement of prey (Gregory et al., 1989). However, one important difference between electroreception in the platypus and the echidna is linked to the difference in their behavioural ecology; while the platypus hunts under water, echidnas are terrestrial and mainly feed on ants and termites. Because air does not conduct electricity, the electroreceptors of the echidna are not able to sense electrical stimuli easily. However, their hunting strategy, which involves digging through soil with their

snouts in search of insect prey, enables them to use the damp soil as an electrically conductive medium through which they can perceive electrical cues (Gregory et al., 1989).

The short-billed echidna, which inhabits drier habitats, seems to depend less on electroreception, something which is reflected in its physiology; this species has only 400 electrosensory receptors compared to the 2000 of the long-billed echidna (*Zaglossus bruijini*), which inhabits wet tropical forests, and the 40,000 of the semi-aquatic platypus (Pettigrew, 1999). The receptors of the two echidna species are concentrated at the end of the bill, reflecting their behaviour of probing in soil to detect prey (see fig. 1.6).

Several other semiaquatic vertebrates have also been shown to use passive electroreception. These include another mammal, the star-nosed mole (*Condylura cristata*) (Gould et al., 1993), and many species of amphibian. The former inhabits damp soil and its burrows often end below water, and so the moist environment aids with the transmission of electrical information. In the amphibians, electroreception is so far only known in salamanders (order Urodele) and larvae of caecilians (order Gymnophonia),

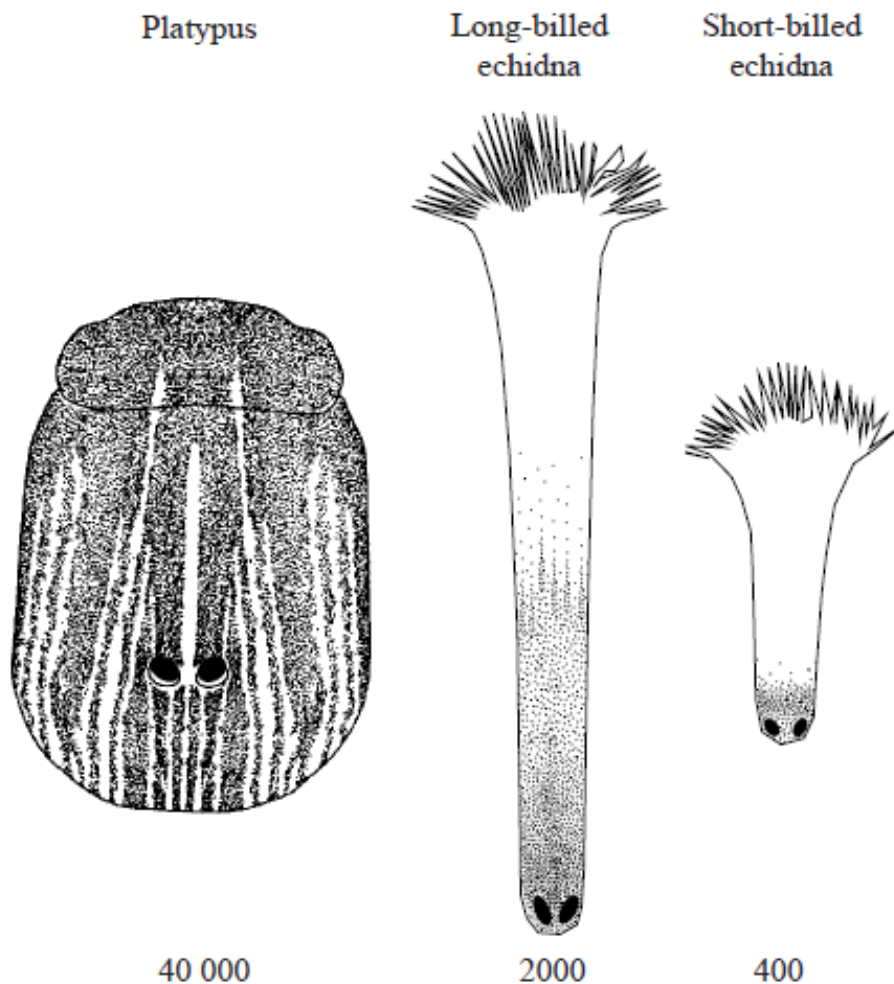

Figure 1.6 – The bills of the platypus (*Ornithorhynchus anatinus*), long-billed echidna (*Zaglossus bruijini*) and short-billed echidna (*Tachyglossus aculeatus*) showing the number and location of electrosensory receptors. Reprinted from “Electroreception in monotremes”, by J. Pettigrew, 1999, *Journal of Experimental Biology*, 202(10), p. 1450.

although it is thought that some species of gymnophiones may retain their ampullary organs into adulthood (Fritzsche & Wake, 1986).

Although not all completely aquatic, all of these species use electroreception in moist environments, and therefore make use of the conductive properties of ions in water. Aerial electroreception requires a different mechanism to be viable as air is an electrical insulator and does not conduct electricity.

### 1.3 – Electroreception in aquatic invertebrates

The possibility of electroreception in invertebrates had for a long time been discounted for a number of reasons, such as the fact that the hard exoskeleton would make electroreception inefficient (Patullo & Macmillan, 2010), but in 2007 two separate studies were published showing different species of crayfish responding to ambient electric fields (Patullo & Macmillan, 2007; Steullet et al., 2007).

The first study detailing a potential electric sense in crayfish came from Patullo and Macmillan in 2007. Crayfish of the species *Cherax destructor* were exposed to a variety of different electrical stimuli designed to emulate those produced by conspecifics, prey and predators. In all of these tests, *C. destructor* responded significantly more often than in control experiments, though interestingly their response to the ‘predator’ stimulus was lowest of all, suggesting that this species is more likely to use electroreception to receive signals from conspecifics and detect prey than to avoid predators (Patullo & Macmillan, 2007). However, although the patterns of the electrical test stimuli were designed to emulate natural stimuli, the strength of the fields produced was much higher than will occur in a natural setting. Though this study does provide evidence of an electric sense in *C. destructor*, the evidence is insufficient to determine how this sense is used in the behavioural ecology of the crayfish (Steullet et al., 2007).

In their 2007 study, Steullet *et al.* observed similar responses in a different species of freshwater crayfish, *Procambarus clarkii*. They noted that *P. clarkii* responded to the stimulation with feeding behaviours such as grabbing and tugging at the electrodes with its claws (Steullet et al., 2007). However, as with Patullo and Macmillan, the field strength required to elicit such behaviour was higher than the fields which would be produced by the prey species and so it was concluded that, though they do have some degree of electroreceptive ability, *P. clarkii* has not evolved a high sensitivity electric sense adept at locating prey (Steullet et al., 2007).

In a further study in 2010, two species of crayfish (*C. destructor* and *C. quadricarinatus*) responded behaviourally to the presence of biologically relevant low-level electric fields (Patullo & Macmillan, 2010). However, these responses only occurred in a small number of the trials so additional research is required to further understand this sensory modality. Intriguingly, the behaviour that was observed did not seem to be a response to a specific situation (e.g. to the presence of prey); the authors hypothesised that whereas in vertebrates the electric sense seems to infer highly specific information, in the crayfish this sense



merely signals the proximity of *something* biologically relevant, and the crayfish must then use other senses to elucidate further (Patullo & Macmillan, 2010).

To date, crayfish are the only aquatic invertebrates known to have an electroreceptive ability. However, due to the fact that the possibility of electroreception in invertebrates has been overlooked for so long, and bearing in mind the abundance of electrical information in an aquatic environment, it is likely that there are many more species of aquatic invertebrate able to sense and make use of electric fields in their surroundings that are yet to be identified.

#### **1.4 – Aerial electroreception**

Saltwater, and to a lesser extent freshwater, conduct electricity via movement of ions. Air, however, is electrically insulative and therefore poses an obstacle when considering aerial electroreception. The ampullary receptors found in many electroreceptive fish rely on an electrically conductive medium. As there is no conduction of electric potential in air, these would be non-functional out of water.

Some organisms have, however, evolved solutions which allow them to take advantage of electrostatic forces. However, to understand the electrical interactions between organisms and their environment, we must first consider the wider electrical landscape, or electric ecology.

##### **1.4.1 – Electric ecology**

A vertical electrical field known as the atmospheric potential gradient (APG) exists between the surface of the earth and the ionosphere, a part of the upper atmosphere (Rycroft et al., 2000). The APG is generated and maintained by the numerous (>3000 daily) electrical storms occurring all over the globe, and the bombardment of the high altitude ionosphere by cosmic rays (Rycroft et al., 2000; Rycroft & Harrison, 2012). At ground level in fair weather in a flat, open area, the electric potential increases by ca. 100 V per 100cm altitude, increasing towards a maximum of approximately 300kV at 30-50km altitude (Clarke et al., 2017). Whilst in fair weather the electric field can be measured to amount to 100-120 V/m, in unsettled or stormy weather, it can greatly vary, sometimes reaching large positive and negative values ( $\pm 14\text{kV}\cdot\text{m}^{-1}$ ; Bennett & Harrison, 2007)

Due to the air's positive potential, negative charge accumulates on the surface of the earth through electrostatic induction – the redistribution of the electric charge on an object when in proximity of a charged object (Clarke et al., 2017; Faraday, 1843). Objects that are conductively linked to the earth ('earthed') also accumulate negative charge through induction in response to the positive potential of the surrounding air, and the further into the field that the object projects, the greater the difference in potential, in line with the aforementioned increase of electric field with altitude.

As flying insects often have a positive electric charge (Clarke et al., 2013; Montgomery et al., 2019), when coming into proximity with an earthed object which has a negative electric potential, an electric field forms between the two objects. It is this interaction which certain invertebrates are known to be able to sense and gain biologically relevant information from.

It is worth noting that the geometry of an electric field is linked to the shape of the charged object. Sharp spikes have a high charge density at their tip as charge density is inversely proportional to the radius of the curvature of a surface. High charge density results in a large electric field around that point, and therefore differently shaped objects can result in different distortions in the electric field around that object.

#### **1.4.2 – Electroreception in *Bombus terrestris***

In 2013 a group of researchers at the University of Bristol demonstrated that buff-tailed bumblebees (*Bombus terrestris*) were able to learn the presence of electric fields applied to artificial electrified flowers in laboratory conditions (Clarke et al., 2013). This ground-breaking study definitively showed that despite the insulating properties of air, some animals are able not only to sense electrical stimuli through the air, but also to make use of this ability to glean information about their surroundings. Bees were shown to be able to differentiate between different shaped electric fields, for example a uniform field versus a ‘bull’s-eye’ polarised field. As field shape is determined by the shape of an object, this finding bears significance for the functionality and evolution of electroreception; could it be that bees have learnt to identify certain shapes of floral electric fields as being from more rewarding flowers? Or conversely, could plants have evolved certain shapes in order to optimise their electrical ‘footprint’ and be more attractive to bees?

Bees were also trained to associate coloured targets with a rewarding or aversive treatment, both in the presence and absence of electric fields. When electrical information was available, bees were better able to accurately discriminate between the rewarding and nonrewarding targets; additionally, the speed with which bees learnt which coloured targets were rewarding and which were aversive was significantly greater when electrical stimuli were provided (Clarke et al., 2013). This means that the information gained through the detection of electric fields is not processed in isolation by the nervous system but contributes to the overall multisensory experience of bees interacting with flowers.

A paper in 2016 expanded on the previous study with details of the potential mechanism of electroreception used by *B. terrestris*. Two structures were identified as potential receptors: antennae and filiform hairs. Both of these structures move like stiff rods which pivot at the base, which in the case of the antenna is the flagellum-pedicle joint, and in the filiform hairs is the base of the hair (Sutton et al., 2016). Due to their shape and the tendency of insect cuticle to become positively charged (Montgomery et al., 2019), the hairs have a high positive charge density enabling them to undergo motion in response to

ambient electric fields. At the base of the hair is a force-sensitive transducer, and the mechanical movement of the hair stimulates a nerve impulse (Koh & Robert, 2020; Sutton et al., 2016).

The study used noncontact laser Doppler vibrometry (LDV) and electrophysiology to determine which, if any, of these mechanisms is responsible for electroreception in *B. terrestris*. The LDV revealed that both the antenna and the filiform hairs moved when in the presence of electric fields of biologically relevant magnitudes (Sutton et al., 2016). However, there were significant differences in the velocity of vibration and the angular displacement (movement relative to the length of the structure), with the antenna vibrating more slowly and with a smaller angular displacement (Sutton et al., 2016). The latter is important as angular displacement is proportional to the strain on the mechanoreceptor, and therefore may be linked to the threshold at which a neural response is produced. Additionally, hairs were found to move in response to a broader range of frequencies of electrical stimulation (Sutton et al., 2016), which could be important when considering the function of electroreception in *B. terrestris* and the characteristics of the electric fields likely to be biologically relevant.

Although both the antenna and filiform hairs responded mechanically to the presence of an electric field, only the hairs were found to elicit a neural response in *B. terrestris*. The mechanoreceptors innervating filiform hairs were found to have an increased neural firing rate in response to the presence of an electric field, something which was not found in the antenna. This evidence suggests that the filiform hairs, rather than the antennae, are the electroreceptive sensors in *B. terrestris*.

The study also highlighted the importance of charge on the bee; hairs on charged bees responded with significantly greater amplitude than those on uncharged bees (Sutton et al., 2016). It has been revealed that the vibrational velocity of filiform hairs is directly proportional to the charge of the bee, and the mechanical effect of electric fields on filiform hairs is greater in conditions conducive to accumulation of charge by the bee (Koh et al., 2019). Charges on bees are likely to be higher in nature than were measured

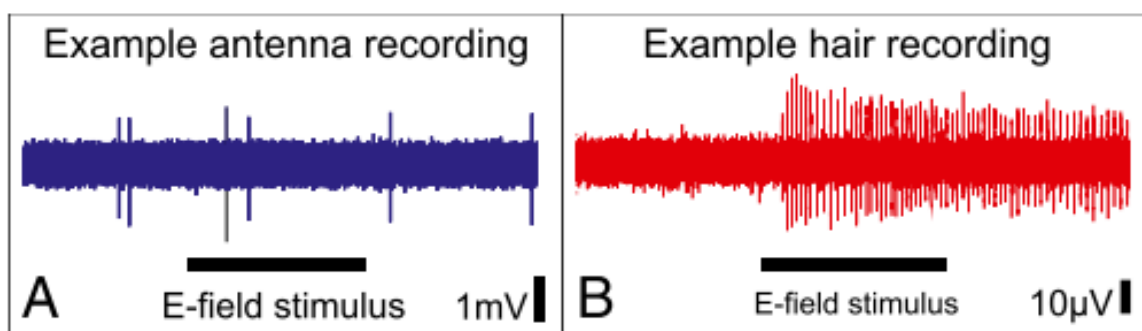

Figure 1.7 – Intracellular electrophysiological recordings of the antenna (A) and filiform hair (B) of a bumblebee, *Bombus terrestris*, in response to an electric-field stimulus. The filiform hair responds with an increased neural firing rate whereas the antenna shows no response to the stimulus. Adapted from “Mechanosensory hairs in bumblebees (*Bombus terrestris*) detect weak electric fields”, by G. Sutton, D. Clarke, E. Morley and D. Robert, 2016, *Proceedings of the National Academy of Sciences of the United States of America*, Volume 113(26), p. 7264.

in lab conditions, so it is likely that the electric sense is more sensitive than previously thought (Montgomery et al., 2019).

### 1.4.3 – Other species

Aerial electroreception has been observed in a number of other invertebrate species. A number of studies on the American Cockroach (*Periplaneta americana*) have revealed that this species is able to sense the presence of electric fields, and reacts with behavioural avoidance and orthokinesis (Hunt et al., 2005; Jackson et al., 2011; Newland et al., 2008). Electric fields were observed to cause deflection in the insects' antennae, and ablation of the antennae or fixation of the antennal joints prevented the cockroaches from sensing the presence of the field (Newland et al., 2008). However, the electrical stimuli presented in these studies were of a much higher magnitude than those likely to be experienced in a natural environment. As this species usually remains at or near to ground level, it is likely to be exposed to electric potentials of 100V or less. The behavioural response seen by the insects was only observed when they were exposed to voltage potentials of 2kV and above (Jackson et al., 2011; Newland et al., 2008). Therefore, although this species has been shown to be able to detect some electrical stimuli, it remains unclear whether this sense is useful in a biological context.

A similar orthokinetic response was seen in both flies and wasps in response to electric fields, but of much lower strengths than those used in the previously described experiments. The parasitic wasp *Itopectis conquisitor* halted movement when it encountered electric potentials of 30-100V (Maw, 1961), and the movements of the fly *Drosophila melanogaster* were significantly reduced when presented with a 30V electrical stimulus (Edwards, 1960). Interestingly, the latter experiment compared the responses of two different fly species – the aforementioned *D. melanogaster* and *Calliphora vicina* – to the same electrical stimuli. While 30V was enough to elicit a significant response from *D. melanogaster*, *C. vicina* only began showing a slight response to a stimulus of 1350V (Edwards, 1960). This apparent difference in electrosensitivity between the two Diptera species demonstrates that there may be differences in the uses or functions of electric field perception between these species, dependent perhaps on differences in their ecology.

While the above examples have all shown aversive behavioural responses to electrical stimuli, some arthropods are known to respond to electric fields in a positive and ecologically relevant way. The presence of a vertical electric field has been shown to elicit a behavioural response in spiders (*Erigone*). Spiders can disperse over long distances by using a behaviour called 'ballooning' whereby a silken thread is let out and moved by electrostatic forces in the APG (Morley & Robert, 2018). When presented with a vertical electric field of  $6.25\text{kVm}^{-1}$  adult *Erigone* spiders carried out behaviours linked to ballooning, indicating that they are able to sense the presence of the electric field and use this information to inform their behaviour (Clarke et al., 2017).

Like *B. terrestris*, spiders possess mechanosensory hairs (known as trichobothria) which are thought to be the sensory mechanism responsible for electroreception. The trichobothria, known for their role in air-flow and noise detection, were found to be displaced in response to electrical fields (Morley & Robert, 2018). Because of their known function as mechanoreceptors, the movement of the trichobothria in response to electrical stimulation is likely to induce a neuronal response, provided the movement meets the neural response threshold. Due to the phylogenetic distance between spiders and other known electroreceptive arthropods, this discovery suggests that electroreception may be widespread.

Finally, honeybees (*Apis mellifera*) have also been shown to have the ability to learn the presence of both constant and modulating electric fields (Greggers et al., 2013). Investigations into the mechanism of electroreception in this species indicated that the antennae are important for electroreception in honeybees, specifically movement of the antennae at the pedicel and basal joints. A conditioned proboscis extension response to electrical stimuli was significantly lower when the joints of the antenna were fixed with wax (Greggers et al., 2013). This is notably different from the findings in *B. terrestris*, possibly suggesting independent evolution in the two species. However, filiform hairs were not considered as potential receptors in *A. mellifera*, and their response to electrical stimuli was therefore not tested. It could be that antennal electrosensing has been lost in *B. terrestris* or the hair response lost in *A. mellifera*, so despite apparent differences in the mechanisms responsible for electrosensing in these two species, it may still have a common origin in both.

### **1.5 – Electrostatics and pollen transfer**

For many decades it has been hypothesised that electrostatic forces may be involved in pollen transfer. This possibility is intriguing, not only because of the potential implications for pollination ecology and evolution, but also from a commercial perspective: as pollination is limited in indoor growing environments, the possibility of electrostatic pollen transfer could enable improvement of artificial pollination methods (Dai & Law, 1995).

In 1982, Corbet *et al.* demonstrated that the presence of an electric field could cause oilseed rape pollen to move between two electrodes, and the distance of this movement increased as the square of the voltage applied was increased (to a maximum distance of 0.5mm). This study also highlighted the low impedance pathway between the stigma of a flower and earth, suggesting that the electric field concentrates at the stigma (Corbet et al., 1982; Vaknin et al., 2000). This is consistent with our knowledge of the physics involved: as electric charge density is highest on sharp or pointed structures, the thin protruding stigma should indeed cause a concentration of the electric field. Additionally, with this being the case, charged pollen will be drawn towards the stigma, increasing the chances of pollination.

A 2017 study demonstrated this hypothesis by tracking the movement of individual pollen grains between a charged acrylic rod and an earthed flower (Clarke et al., 2017). Bi-directional pollen transfer was

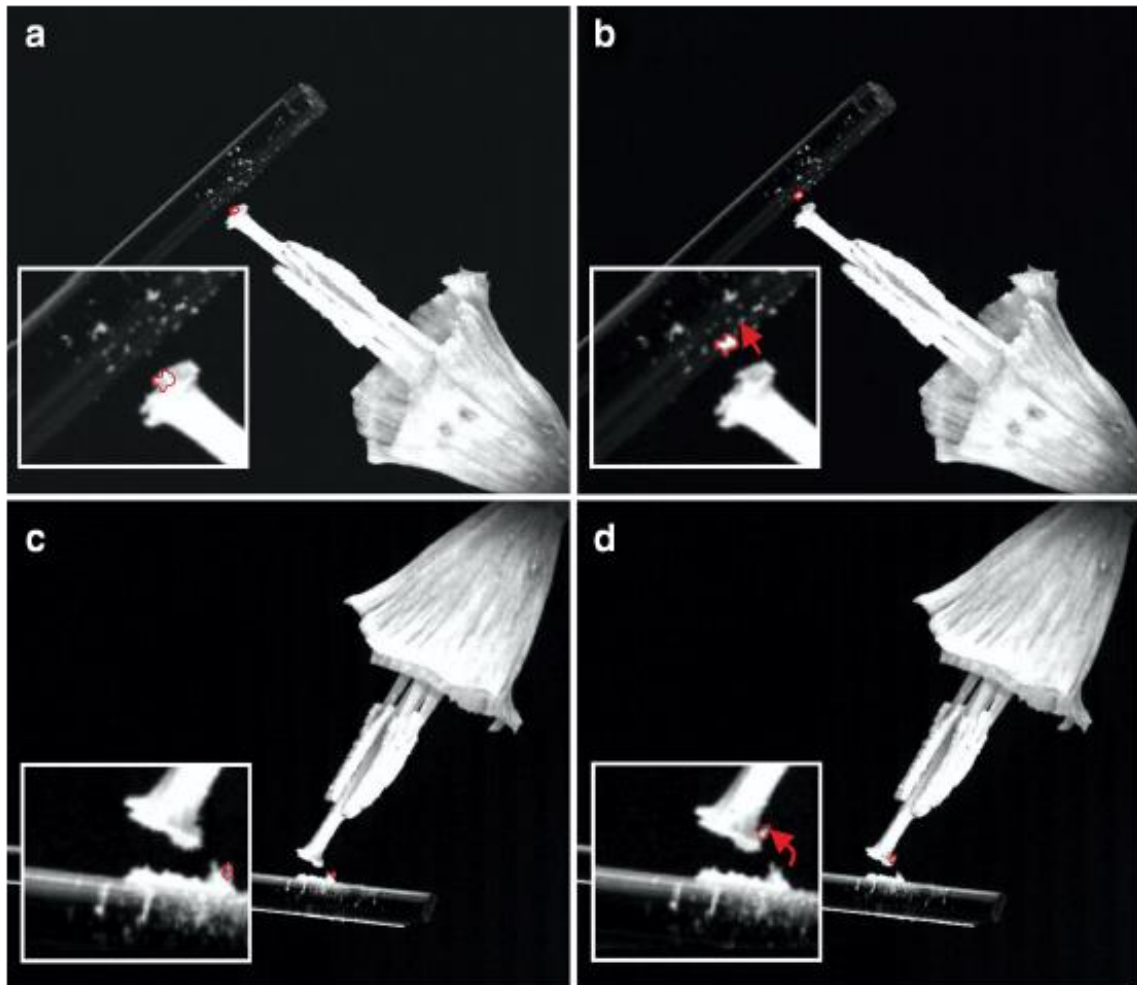

Figure 1.8 – Electrostatic forces between a charged acrylic rod and an earthed flower elicit bi-directional pollen transfer. Reprinted from “The bee, the flower, and the electric field: electric ecology and aerial electroreception”, by D. Clarke, E. Morley and D. Robert, 2017, *Journal of Comparative Physiology A*, Volume 203(9), p. 745.

observed, and the electric field that exists between a charged rod and a flower was shown to be more influential than the force of gravity (Clarke et al., 2017).

Pollen grains smaller than and equal to the mass of maize pollen are subject to significant electrostatic forces (Clarke et al., 2017). These electrostatic forces exist on pollen attached to insect pollinators and on pollen in the air, indicating the possibility that electrostatic interactions facilitate wind-pollination (Bowker & Crenshaw, 2007).

### 1.5.1 – Buzz Pollination

Some flowers require their anthers to be vibrated at certain frequencies in order to initiate the release of pollen; bumblebees use contraction of their wing muscles to produce such vibration in a process known as sonication or buzz pollination (Buchmann, 1985; De Luca & Vallejo-Marín, 2013). Buzz pollination is not insignificant, being known to occur in up to 20,000 plant species including commercially important plants such as tomatoes and potatoes; however, only a small proportion of pollinating insects (>50 genera

of bee and one known species of hoverfly) are able to carry out floral sonication (De Luca & Vallejo-Marín, 2013). Bumblebees are one of the insect genera capable of buzz pollination, and so are key to the reproduction of many plant species.

Because of the muscle contractions involved in producing the ‘buzz’ for buzz pollination, this behaviour may cause an increase in the charge of the bee, potentially increasing the strength of the electrostatic interactions between the bee and the pollen. While already known to be an efficient method of pollination due to the prevention of loss of pollen to air currents (Buchmann, 1985), the potential for an increase in the effect of electrostatics could maximise efficiency of pollen transfer and therefore have implications for the fitness of buzz pollination dependent plants.

## **1.6 – Conclusion**

The ubiquity of electrical information in both marine and terrestrial environments makes electrosensing a potentially valuable ability which many species are known to have developed. However, while the sense is known in a large number of species, it is likely to be far more widespread than is currently evidenced, particularly in terrestrial environments. This thesis uses *Bombus terrestris* as a study species to explore some of the potential behavioural and ecological functions of aerial electroreception through evaluation of the spatial resolution of electrosensing and detailed examination into the way other senses impact the interactions between this species and its environment.

## Chapter 2: The natural history and sensory ecology of *Bombus terrestris*



## 2.1 – Introduction

Bumblebees (Hymenoptera: Apidae, Bombini) are a tribe of large, hairy bees mainly found in the Northern Hemisphere (D. Goulson, 2010). *Bombus terrestris*, the buff-tailed bumblebee, is native to Europe and is one of the most common bumblebee species found in the UK. This species is considered a model organism due to the wealth of literature examining its biology and ecology; this, along with the evidence for electroreception in the species discussed in Chapter 1, makes it the ideal focal species for this study. This chapter will explore some of the existing research into the natural history and behavioural ecology of *Bombus terrestris*, providing an insight into the importance and functions of different sensory systems in this bee.

## 2.2 – Ecology and Natural History

*Bombus terrestris*, along with 134 other of the world's ca. 250 bumblebee species, is primitively eusocial, having small, short-lived colonies with overlapping generations and a division of labour between castes (Ayasse & Jarau, 2014; Goulson, 2010). *B. terrestris* colonies live in nests which are mainly built below ground, though they can be found nesting on the ground surface or above ground, such as in tree hollows (Goulson, 2010; Lye et al., 2012). Colonies are founded in spring by overwintering queens (Goulson, 2010; Prÿs-Jones & Corbet, 1987). Initially, workers are produced to raise young, maintain and defend the nest and to forage. However, later in the season at a point known as the 'switch point' the queen produces eggs which will develop into both males and young queens, both of which leave the nest to mate and found new colonies (Ayasse & Jarau, 2014; Prÿs-Jones & Corbet, 1987). At its peak, a buff-tailed bumblebee colony will consist of up to 350 workers (Goulson, 2010; Prÿs-Jones & Corbet, 1987); interestingly, bumblebee workers show extraordinary variation in size, with the smallest *B. terrestris* workers having a mass up to eight times smaller than the largest workers, even within the same colony (Goulson, 2010). This is thought to be partially due to foraging efficiency. Bees with long tongues feed more slowly on shallow flowers than bees with short tongues. As tongue length in *B. terrestris* is proportional to body size, variation in body size among workers provides foragers with a variety of tongue lengths able to feed optimally from a wider variety of flower types (Peat et al., 2005).

Bumblebees forage for nectar and pollen from flowers to feed themselves and supply to the colony. While some species of bee are specialists, preferring to visit a small group or a single flower species, *B. terrestris* is one of the most generalist bee foragers, utilising a wide range of flower species (Goulson, 2010; Knight et al., 2005). The species is relatively short-tongued; there seems to be a negative correlation between tongue length and diet breadth, with short-tongued species being able to forage on a higher diversity of flowers and longer-tongued species tending to specialise more on certain plant groups (Goulson et al., 2008; Goulson & Darvill, 2004). However, in the instance that the corolla of a flower is too deep, the buff-tailed bumblebee, along with several other species of bumblebee, is liable to cheating;

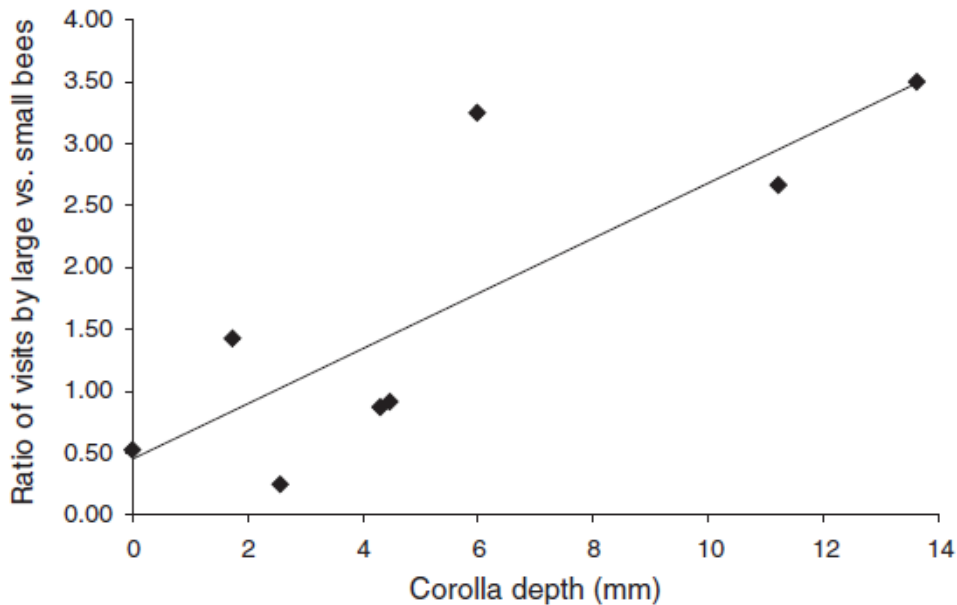

Figure 2.1 – The ratio of large to small *B. terrestris* workers recorded visiting eight plant species, plotted against corolla depths of the plants. Reprinted from “Does intraspecific size variation in bumblebees allow colonies to efficiently exploit different flowers?”, by J. Peat, J. Tucker and D. Goulson, 2005, *Ecological Entomology*, 30(2), p. 179.

the bees will bite holes in the corolla of the flowers to access the nectar while bypassing the sexual organs of the plant (Goulson, 2010). Despite this, many studies have found that such nectar robbing bees are often still effective pollinators, so this behaviour often does not have adverse effects on the fitness of plants.

When returning to the nest after foraging, bees perform ‘excited runs’ through the nest, thought to recruit other foragers to the same food source (Ayasse & Jarau, 2014; Goulson, 2010). These runs often involve physical contact between bees, and the amount of contact increases when food reserves are low, indicating its importance in maximising forager recruitment (Ayasse & Jarau, 2014). During these excited runs, the bees emit recruitment pheromones which are sensed by nestmates and signal the need for increased numbers of foragers. This is an example of how the sensory systems of bees are important for intraspecific communication.

### 2.3 – Sensory Ecology

Like all animals, *Bombus terrestris* uses sensory systems to gain information about its environment, and this information goes on to inform its behaviour. The primary sensory modalities known to be used by bees seem to be vision and olfaction, though they possess many other sensory abilities which are used in specific contexts, such as fluid-flow and temperature sensing. Below I examine the mechanism and function of different sensory modalities in the buff-tailed bumblebee.

### 2.3.1 – Vision

Much of the literature exploring bee vision has focussed on *Apis mellifera*, the Western honeybee. However, in recent years there has been further research into many aspects of vision in bumblebees, particularly focussing on colour vision and vision-mediated behaviour.

Visual information underpins many important behaviours in *Bombus terrestris*. As well as being imperative for navigation, foraging and homing, amongst other behaviours, vision has also been shown to be necessary for bumblebee flight (Meyer-Rochow, 2019). Because of this, it must be considered one of the most important sensory modalities for this species.

In order to understand how visual information informs bumblebee behaviour, it is necessary to consider both the physiology of the visual organs and the different aspects of vision.

Bumblebees possess five eyes: two lateral apposition compound eyes and three small dorsal ocelli on the frons of the head capsule. The compound eyes of the bee are each made up of ca. 6000 ommatidia, each of which is approximately 26µm in diameter (Meyer-Rochow, 2019). Unlike honeybees, bumblebees do not possess well-developed inter-ommatidial hairs, giving the surface of the eye a smooth appearance. The ommatidia are made up of a hexagonal facet above a columnar structure called a rhabdom which contains photopigment molecules in its membrane; this membrane consists of thousands of microvilli to maximise the surface area for light absorption (Meyer-Rochow, 2019).

*Bombus terrestris* has trichromatic colour vision. Each rhabdom is made up of eight cells; six cells contain green-sensitive photopigment (~540nm) in their membranes, one contains blue-sensitive (~440nm) and one, UV-sensitive (~350nm; Dyer & Chittka, 2004). The ocelli are sensitive to UV and green light, but are not capable of forming an image and appear to act as sensors to monitor light levels (Meyer-Rochow, 2019).

Colour is a very important stimulus informing foraging behaviour in bees, with many aspects of floral colouration containing information. When initially searching for flowers and approaching from a distance, the most important floral colour characteristics are the spectral purity of the corolla and the contrast between the corolla and the background (Lars Chittka et al., 2009; Lunau, 1992). However, at close range, other cues, such as pattern and the presence of nectar guides become more important (Lunau, 1992). Nectar guides (patterns on the corolla directing the pollinator towards the nectar source), which are often UV-reflective (fig. 2.2; Schulte et al., 2019), have been shown to significantly decrease handling time of flowers by bees (Leonard & Papaj, 2011). This benefits both the plant and the bee; the shorter the amount of time taken to collect nectar, the higher the potential visitation rate to each flower and so the higher the rate of pollen movement between plants. Short handling times also result in a higher net gain for the bee, as less energy is expended in attaining the reward.

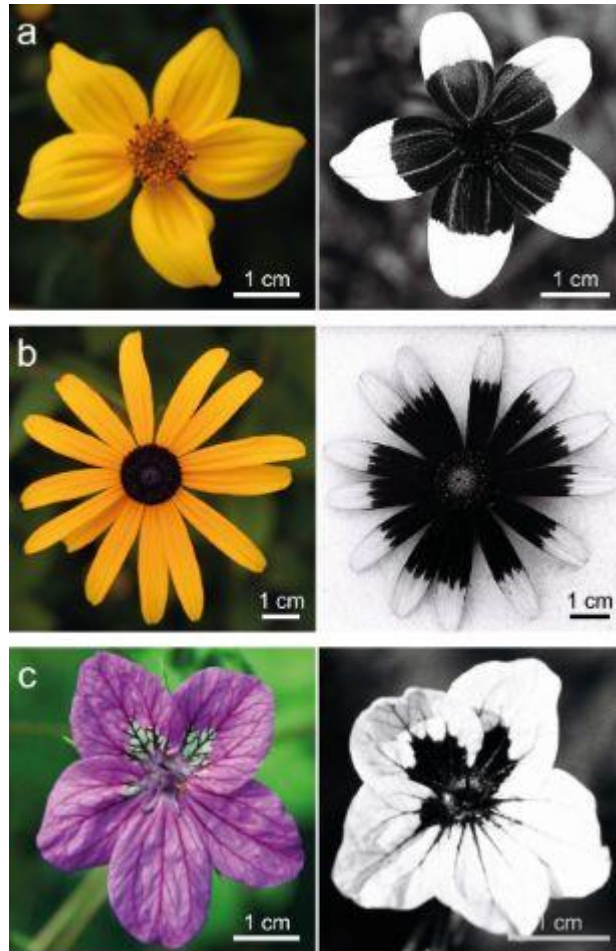

Figure 2.2 – Photographs of three flowers under visual (left) and UV (right) light conditions. Flowers shown are a) *Bidens ferulifolia*, b) *Rudbeckia fulgida*, and c) *Erodium manescavii*, all of which are pollinated by insects, including bumblebees. Reprinted from “Ultraviolet patterns of flowers revealed in polymer replica – caused by surface architecture”, by A. J. Schulte, M. Mail, L. A. Hahn and W. Barthlott, 2019, *Journal of Nanotechnology*, Volume 10, p. 461.

Additional visual characteristics of flowers that are important for foraging behaviours include flower size, height, flower shape and whether flowers are clustered or alone (Parachnowitsch et al., 2012; Spaethe et al., 2001). Unlike the ocelli, the compound eyes of bumblebees are able to discern shapes and fine details. This ability is known as spatial resolution or visual acuity. The spatial resolution of bumblebee vision is constrained by both the physical properties of the eye, in particular the inter-ommatidial angle, and the subsequent processing in the visual processing centre of the brain (Spaethe et al., 2001). Several studies have attempted to quantify the resolution of *B. terrestris* vision using both physiological and behavioural approaches, but have produced a variety of different estimates (Chakravarthi et al., 2016; Macuda et al., 2001; Spaethe et al., 2001; Taylor et al., 2019).

While resolving power does vary due to a number of factors such as motion or contrast between an item and its background (Chakravarthi et al., 2016; Spaethe et al., 2001), another reason for this disparity may

be due to the body size variation within *B. terrestris* colonies. A recent study has used x-ray microtomography to observe how different morphological characteristics of the eye vary with bee size, and how this is likely to affect the vision of the bumblebee (Taylor et al., 2019).

Eye size increases as the body size of a bee increases, though these two values are not proportional; the scaling exponent of the eye surface area was found to be 0.45 whereas that of body mass was found to be 0.73 (Taylor et al., 2019). Although the eye takes up a smaller proportion of the body of a larger bee, the eyes themselves are still larger in a larger bee. The larger bee eyes contain more ommatidia than the smaller ones, improving the visual acuity. Additionally, there appears to be an area of improved resolution in the dorso-frontal region of the compound eye, similar to the ‘acute zone’ found in honeybee eyes (Taylor et al., 2019).

Along with increased visual acuity, larger bees also have increased optical sensitivity because of the increase in diameter of the ommatidial facets and an increase in the length of the rhabdom (Taylor et al., 2019). This essentially means the eyes of the larger bees capture more photons and are therefore able to see at lower light levels. This is supported by observations that larger bees are able to go on foraging later into the evening than smaller conspecifics or other pollinators (Meyer-Rochow, 2019; Taylor et al., 2019).

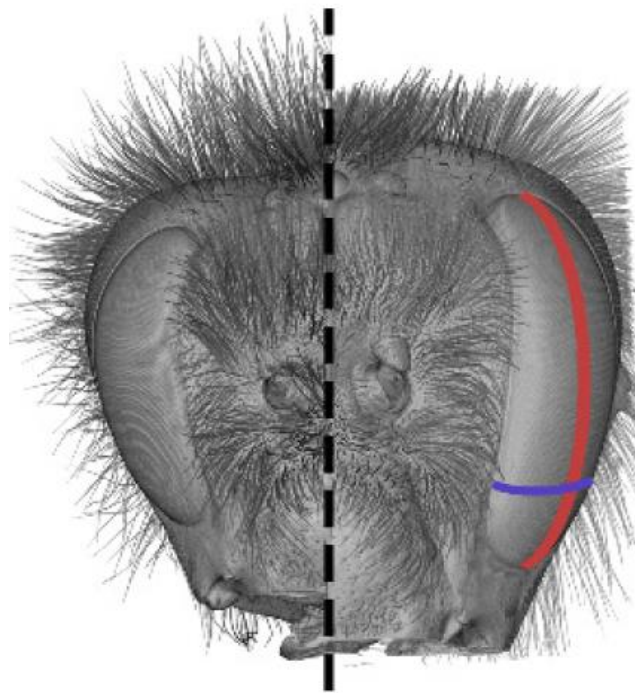

Figure 2.3 – Volume rendering of the dried heads of a small (left) and large (right) *B. terrestris* worker from the same colony. Adapted from “Bumblebee visual allometry results in locally improved resolution and globally improved sensitivity”, by G. Taylor, P. Tichit, M. Schmidt, A. Bodey, C. Rau and E. Baird, 2019, *eLife*, 8, p. 4

Bumblebees are known to be able to perceive the polarization of light using a region of the compound eye known as the dorsal rim area (DRA; Foster et al., 2014). Polarized light is a potentially rich information source to be exploited. It has been suggested that the polarization sensitivity of bumblebees could be used in foraging. Buff-tailed bumblebees were shown to be able to learn the polarization patterns on the surface of flowers, but only when viewed from below (Foster et al., 2014). As many species of flower do not face upwards (Foster et al., 2014; Rands et al., 2011) it is possible that this ability is used during foraging; however, further evidence is required, perhaps focussing on the use of polarised light in natural situations.

Another potential function of polarized light sensitivity in *B. terrestris* is navigation. In navigation, both skylight polarization patterns and observation of landmarks are valuable sources of information (Foster et al., 2014; Goulson, 2010; Goulson & Stout, 2001). However, the latter seems to be more important in this scenario; when displaced away from their nest area, buff-tailed bumblebees were able to home from distances of up to 9.8km. They achieved this by flying in a gradually increasing spiral, and it has been suggested that this behaviour demonstrates bees searching for recognisable landmarks from which they can navigate back to the nest (Goulson & Stout, 2001).

Another aspect of vision which could function in navigation is the field of view (FOV); large FOVs have been shown to be advantageous for visually mediated behaviours such as navigation and motion detection (Taylor et al., 2019). As with resolution and sensitivity, an increase in bumblebee eye size results in an increase in the FOV. Furthermore, not only does the FOV increase in size, but two areas of binocular overlap are created: one frontally and one dorso-frontally (Taylor et al., 2019). The positioning of these areas is indicative of the potential advantages of this overlap; when approaching a flower from below it will be viewed dorso-frontally, and the binocular overlap in this region may assist the bee in assessing the value of the flower or landing on its surface.

While larger individuals do have areas of binocular overlap, *B. terrestris* appears to be unable to perceive depths using stereoscopic vision. However, in spite of this, they still have the ability to perceive 3D shapes. Bees use the apparent motion of objects to perceive depth; the closer the bee is to an object, the faster the image will move (Lehrer et al., 1988). This ability is achromatic as it is mediated by the green-sensitive colour channel in the bee's eye.

Alongside its role in depth perception, motion perception aids bees in the learning of colour stimuli. When honeybees were presented with different coloured stimuli, the association between the stimulus and reward was more readily learnt when an additional motion cue was provided (Balamurali et al., 2015). While this study did not use *B. terrestris*, it is reasonable to assume a similar association in bumblebees due to the relatedness of the two species and the similarity between their visual systems (Meyer-Rochow, 2019).

It is worth noting that the vast majority of research into vision in *B. terrestris* has been carried out on workers. Bumblebee colonies display polymorphism, having three discrete adult morphologies (queen, worker, male), so it is possible that there is variation in the visual systems between different castes. Future studies could focus on elucidating the visual capabilities of male and queen bumblebees to determine whether there is additional variation in morphology and functionality.

### **2.3.2 – Chemosensory perception**

Sensing chemicals in the environment, whether through the air (olfaction) or by direct contact between the antennae and a substrate, is important for many aspects of bumblebee ecology, informing social behaviour, mating and foraging choices.

Bees produce a vast number of different chemicals which perform a variety of different functions in their biology. Among these, some chemicals, known as pheromones, are specifically produced as chemical signals to provide information to nestmates; however, others are produced to perform different functions, yet their presence in different contexts can provide important information. An example of these cues can be seen in the ‘footprints’ of bees. When they walk across a surface, bees leave chemical footprints, thought to be secreted from tendon glands on the legs (Ayasse & Jarau, 2014; Jarau et al., 2012). The chemical composition of these footprints does not change, but rather the meaning derived from perception of the footprint changes depending upon the context in which it is found (Saleh et al., 2007). Footprints around the entrance to the nest are a valuable indicator of nest location. Although vision plays an important role in navigation and location of the nest, in the event of the vegetation around the nest changing, this olfactory cue may be a more reliable indicator of nest location (Saleh et al., 2007).

In a different context such as on the surface of a flower petal, these footprints serve a different function; the presence of scent marks on petals indicates a flower has been recently visited by another insect, and so is likely to have reduced nectar availability. While bees are able to discriminate between the scent marks of conspecifics and heterospecifics, both influence foraging behaviour (Saleh et al., 2007). The repellent effect diminishes over time, resulting in lower concentrations of the footprint chemicals as nectaries replenish (Goulson, 2010; Luo et al., 2014; Pearce et al., 2017).

In contrast to the above, some laboratory-based studies have found that scent marks on flowers actually have an attractive effect (Ayasse & Jarau, 2014; Schmitt & Bertsch, 1990). However, as hypothesised by Ayasse & Jarau (2014), this is likely to be an artefact of the particular studies; as the artificial flowers used in these studies were refilled immediately after visitation by a bee, the scent marks in this context actually indicated food was available, highlighting the context-dependency of scent marks as a cue (Ayasse & Jarau, 2014).

As mentioned above, bees can produce chemicals called pheromones which have the specific function of providing information to conspecifics, and these are used in a variety of biological contexts. Firstly, pheromones play an important role in locating a mate; male bumblebees patrol regular routes and use pheromones to mark 'buzzing places' at prominent landmarks along the route, such as a tree or a fence post (Goulson, 2010). These pheromones are species specific and therefore are effective in aiding females to locate conspecifics. Virgin queens will wait at the marked buzzing places and produce a sex pheromone from their mandibular glands. The production of the compounds which make up this pheromone peaks in queens between the ages of 3 and 7 days, corresponding with the age at which most mating occurs (Ayasse & Jarau, 2014).

Pheromones are also important in maintaining order within a colony; queens produce pheromones which inhibit the development of the ovaries of workers and prevent the rearing of new queens. Additionally, when larvae are exposed to a queen within their first few days of development they will not develop into a queen, even if provided with the extra food that aids queen development. While the latter occurs even with a single queen encounter, the former relies on a non-volatile pheromone which is produced in the mandibular gland of the queen then groomed onto her body. Workers must have regular contact with the queen in order for the inhibitory effects to remain in place.

Another important function of olfaction in bee ecology is the role it plays in foraging. Thought to have originally evolved to deter herbivores (Pellmyr & Thien, 1986; Raguso, 2009), flowering plants produce an array of volatile compounds, many of which act as pollinator attractants (Parachnowitsch et al., 2012; Raguso, 2009; Schiestl et al., 2011). Floral scents contain complex mixtures of compounds, and the bee's ability to discriminate between these mixtures and between different proportions of compounds within them is key in the role they play as information sources, informing both the recognition of a plant species and the foraging choices made by bees.

In order to optimise foraging behaviour, bees must be able to choose the flowers which yield the highest rewards in terms of pollen or nectar. The odour of pollen provides an indication of its availability in specific flowers, and is therefore potentially important when making foraging choices (Dobson et al., 1999). Indeed, a 1999 study indicated that two volatiles which emanate from rose pollen, eugenol and tetradecyl acetate, play an important role both in prompting bees to land on the flower and to initiate pollen collecting behaviour (Dobson et al., 1999).

Additionally, floral odours play an important role in forager recruitment; when food stores in the colony are low, the presence of food odours inside the nest, alongside a recruitment pheromone, causes an increase in the number of workers leaving to forage, and this effect is greater than the effect of the recruitment pheromone alone (Ayasse & Jarau, 2014; Kitaoka & Nieh, 2009). Furthermore, it appears workers learn the odours of food brought back to the nest and use this to inform their foraging decisions (Ayasse & Jarau, 2014). For example, when anise-scented air was pumped into a *B. terrestris* nest, the



workers of that colony showed a higher preference for anise-scented food when foraging (Molet et al., 2009).

### 2.3.3 – Vibrational sensing

Both vibrational and vibroacoustic sensing deal with the perception of vibrations, such as those caused by an insect moving. However, the former refers to vibrations moving through a substrate or other medium, whereas vibroacoustic sensing refers to vibrations moving through the air in the form of sound.

Insects possess vibration-sensing subgenual organs in their legs which have been shown to be used to detect substrate-borne vibrations in the honeybee, *Apis mellifera* (Hill, 2008). While there is no direct evidence that *Bombus terrestris* uses subgenual organs to detect vibrations, it has been suggested that the post-foraging ‘excited runs’ of bees may provide some kind of vibrational signal to other bees (Hunt & Richard, 2013). This behaviour is also thought to be a mechanism of dispersing recruitment pheromones amongst workers (Ayasse & Jarau, 2014), so perhaps vibration acts as an additional recruitment signal, or perhaps it is just the by-product of movement and does not provide the bees with any information. Further research is required to elucidate whether vibrational communication is present in *B. terrestris*.

As well as the subgenual organs, many insects are known to possess a vibration-sensitive organ called the Johnston’s organ (JO) in the pedicel of the antenna (Hill, 2008; Kirchner, 1993). This is recognised to be the mechanism of vibroacoustic communication (or hearing) in honeybees, and it works by detecting air-particle oscillations (Towne & Kirchner, 1989). *B. terrestris* also possesses a JO, suggesting the potential for a similar hearing mechanism to that of the honeybee. Another possible mechanism for hearing in *B. terrestris* is movement of the mechanosensitive body hairs due to airborne vibrations. When investigating electric field perception in *B. terrestris*, Koh et al. (2019) found that these hairs do vibrate in response to acoustic stimulation. The response of the hairs to the acoustic stimuli was in the same order of magnitude as the response to electrical stimuli, and when played in anti-phase, the two stimuli cancelled each other out, rendering the hair virtually stationary (see fig. 2.4; Koh et al., 2019).

As the mechanical movement of these hairs in response to electric fields elicits a neuronal response, it seems almost certain that hair movement in response to acoustic stimulation will also elicit a neuronal response, though this has not yet been shown experimentally. Bumblebees possess filiform hairs of a variety of different lengths which respond differently to electrical and acoustic stimuli, with longer, thicker hairs showing an increased response to electrical stimuli (K. Koh & Robert, 2020); this suggests different hairs may be optimised to detect different stimuli.

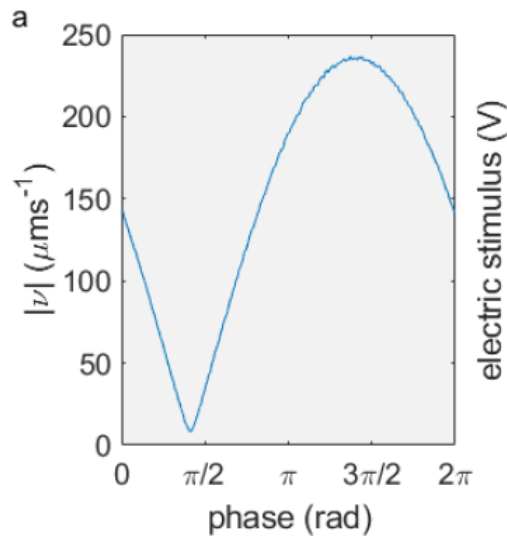

Figure 2.4 – Response of a charged *B. terrestris* filiform hair is of a comparable level to its response to acoustic stimuli. When played in anti-phase ( $\pi/2$ ), the motion of the hair almost ceases. Adapted from “Bumblebee hair motion in electric fields”, by K. Koh, C. Montgomery, D. Clarke, E. Morley and D. Robert, 2019, *Journal of Physics: Conference Series*, Volume 1322(1), p. 3.

Interestingly, the filiform hairs of *A. mellifera* have been shown not to be sensitive to acoustic stimuli (Kirchner, 1993). This could suggest that hairs are not a mechanism for hearing in bumblebees either; however, the same disparity has been seen between the proposed electrosensors of these species. While honeybees were shown to be reliant on their antennae to detect electric fields (Greggers et al., 2013), Sutton et al. (2016) demonstrated that the antennae are not likely to be involved in electroreception in *B. terrestris*. Therefore, it is worth considering the possibility that electroreception evolved independently in these two species, or the possibility that the function of the antennae as electroreceptors has been lost in *B. terrestris*, and likewise the filiform hairs in *A. mellifera*.

Bumblebees are known to produce sound for the purpose of intra- and interspecific signalling. *B. impatiens* has been shown to produce pulses of sound when returning from foraging. Playback experiments revealed that when food is scarce, these sound pulses alone are enough to activate foraging in workers, indicating the role of this sound in intraspecific communication (Su, 2009). *B. terrestris* produces a loud hissing sound as an interspecific warning signal; this hissing occurs when nests are disturbed by vibration or when mammal breath or air currents containing elevated CO<sub>2</sub> pass through the nest (Kirchner & Röschard, 1999). This suggests hissing is a mechanism of deterring predators or nest-site competitors, and experiments using domestic mice (*Mus domesticus*; a nest-site competitor of *B. terrestris*) demonstrate its effectiveness in deterring mammalian intruders (Kirchner & Röschard, 1999).

As bees possess the ability to perceive acoustic stimuli, and are likely also to be sensitive to substrate-borne vibrations, there are a variety of ecological and behavioural contexts in which vibrational stimuli may play an important role, though more research is required in order to explore this further.

### 2.3.4 – Fluid flow sensing

The mechanosensory filiform hairs of other arthropods have been shown to be involved in another sensory modality: fluid flow sensing. This is the phenomenon whereby organisms can sense the motion of a fluid surrounding them (in terrestrial arthropods this fluid is air), and are able to sense perturbations in fluid motion due to the presence of other objects or organisms (Casas & Dangles, 2010; Humphrey et al., 2001; Steinmann et al., 2006). As with the acoustic stimuli discussed above, it stands to reason that any motion of these mechanoreceptive hairs should result in a neuronal response, regardless of the source. Therefore, it is possible that *B. terrestris* uses its body hairs as fluid-flow sensors, though further work needs to be done to investigate the exact role of flow sensing in this species.

Potential functions of fluid flow sensing in arthropods include the detection of moving objects and nearby organisms; in *Bombus terrestris*, this could aid in avoidance of predators such as birds, or parasites such as wasps or flies. Furthermore, fluid flow sensing is likely to be important in control of flight; this has been shown to be true in *Apis mellifera*, though interestingly the Johnston's Organ was deemed to be the primary fluid-flow sensor (Towne & Kirchner, 1989; Towne, 1995).

### 2.4 – Floral cues

Many plants rely on insect pollinators for their reproduction, and so many mutualistic associations have evolved whereby plants provide a reward (nectar) to visiting insect pollinators. In their native habitat, bumblebees are particularly important pollinators with many wild plants being predominantly or exclusively pollinated by bumblebees (Goulson & Darvill, 2004). Additionally, *Bombus terrestris* is often used as a commercial pollinator inside greenhouses (Abak et al., 1997; Ceuppens et al., 2015; de Ruijter, 1997; van den Eijnde et al., 1991).

Because of the importance of pollinators to plant fitness, many plants have evolved mechanisms to advertise their nectar supplies in order to attract pollinators and thereby increase their pollination success. Such mechanisms are known as floral cues, and a multitude of different cues have evolved to take advantage of every sensory system.

Many floral cues are thought to have evolved in response to a pre-existing sensory bias in pollinators. For example, there is some evidence to suggest that trichromatic colour vision in Hymenoptera evolved prior to the evolution of flowering plants (Chittka, 1996), indicating that the attractive colour of flowers evolved in response to the innate preferences of their pollinators.

While colour is important in influencing the foraging decisions of bees (Chittka, 2001; Lunau, 1992), both chromatic and achromatic properties of flowers are known to affect search time when foraging (Spaethe et al., 2001). It appears that bees use different search strategies to locate large and small flowers, relying on colour cues for larger flowers and achromatic visual cues when searching for smaller flowers. The

latter include shape, pattern and the presence of visual pollen stimuli (Krishna & Keasar, 2018; Leonard & Papaj, 2011; Wilmsen et al., 2017).

Non-visual stimuli can also act as floral cues; the scent emitted by flowers is a complex array of different chemicals, and both the presence or absence of a chemical and its relative concentration can provide information to bees about the plant and the potential reward available when visiting it (Ceuppens et al., 2015). However, not all plant volatile organic compounds (VOCs) are attractive to insects; plants often produce repellent VOCs in order to deter phytophagous insects and attract predators such as parasitoid wasps (Schiestl & Dötterl, 2012). Plants with higher concentrations of these anti-herbivory VOCs have been shown to be less attractive to pollinating insects (Ceuppens et al., 2015; Raguso, 2009), suggesting a trade-off is in play whereby plants are trying to maximise pollination and minimise herbivory, both through the regulation of their scent.

Other floral characteristics known to act as cues to pollinators include temperature (Harrap et al., 2017, 2020), humidity (von Arx, 2013; von Arx et al., 2012) and petal microtexture (Kevan & Lane, 1985). Additionally, the presentation of multiple different floral cues (multimodal cues) has an effect on the ability of bees to learn and remember flowers (Clarke et al., 2013; Katzenberger et al., 2013; Lawson et al., 2018).

Oligolectic foragers (those which only forage from one or a few plant species) may have an innate or learnt recognition of the specific floral characteristics of their target plant. However, polylectic species such as *B. terrestris* must be able to recognise flowers using general floral cues, though foragers do learn species-specific floral cues with experience, aiding in the identification of more rewarding plant species (Lunau, 1992).

## **2.5 – Conclusion**

While much is known about the sensory systems of the buff-tailed bumblebee, particularly in the context of foraging, there are still areas in need of further research. The majority of the research to date focusses on vision and olfaction, perhaps because these senses are shared with humans, allowing scientists to relate to their research. However, the way bees experience the world is also shaped by other, more alien senses, such as fluid-flow detection and electroreception. As an emerging area for research, the mechanism and functions of electroreception in *B. terrestris* should be studied in order to provide an insight into the effect of this sense on the way bees perceive and interact with their environment.

# Chapter 3: Methodology

### **3.1 – Introduction**

*Bombus terrestris* has been shown to be capable of detecting and learning the presence of electric fields in a laboratory setting (Clarke et al., 2013, 2017; Sutton et al., 2016). However, while this ability is clearly present, it is yet unknown what function it may play in the bee's biology and ecology. More information is needed to determine the ecological significance of electroreception in bumblebees.

This study aims to explore the spatial resolution of electroreception in *Bombus terrestris*, examining sensitivity to electric fields and ability to glean directional information from electrical stimuli. This information will provide an insight into the potential functions of electroreception by elucidating which ecological situations the sense is likely to be functional in. For example, if electrical information can only be sensed over a short distance then it is unlikely that the behaviour is used in location of flowers from afar, and if bees are found to be able to detect electrical stimuli to the side of them or behind them, it is possible that this information could be used to provide an indication of approaching predators.

A psychophysical approach was chosen for the procedure; this involves using observations of the bees' behaviour rather than taking direct measurements, enabling a better understanding of what the bee itself is perceiving. The data can therefore be used as an indicator as to at what point stimuli are 'biologically relevant', providing the bee with useful and functional information.

The basis of this approach is the habituation-dishabituation paradigm, a well-established experimental procedure which makes use of habituation – the attenuation of the behavioural response to a repeated stimulus. This method relies upon the application of a stimulus that elicits a consistent behavioural response and which the study organism can become habituated to, and this is known as the habituation stimulus (*h*). In the course of developing this procedure, several alternative stimuli were considered for *h*. An electrical stimulus and PER were both found to be unsuitable for this purpose, but a tactile stimulus proved appropriate and has been proposed for use in further experimentation.

### **3.2 – Experimental design**

#### **3.2.1 – Bees**

Experiments were carried out using *Bombus terrestris* colonies from Koppert, UK. The colonies were housed in a plastic nest box inside a cardboard box which was connected to a 72 x 104 x 30 cm flight arena via a plastic tube. The arena had a lid of UV-transparent Perspex and the floor was covered with green tape to mimic vegetation. Bees were kept on a 12 hour light-dark schedule and light was provided by six cold light (3200K) LED panels (Sylvania, Germany).

#### **3.2.2 – Harness design**

When exploring the spatial resolution of the electric sense, it is necessary to restrain the bees to make it

possible to accurately manipulate the positioning of the stimulus relative to the bee's body. Traditionally, the harnesses which restrain bees during experimentation consist of a metal, glass or plastic tube with something holding the bee's head in place such as a small strip of duct tape (e.g. Bitterman et al., 1983; Matsumoto et al., 2012). Although some studies have used slightly different restraining techniques, generally involving a tapered tube out of which the bee's head protrudes (Abou-Shaara, 2018; Kaspi & Shafir, 2013), the method described above is now widely accepted as standard (fig. 3.2).

This tube-type restraint is an unsuitable design for this study as it obscures much of the surface of the bee's body. A study in 2016 demonstrated that *B. terrestris* uses mechanosensory filiform hairs on the dorsal surface of the head to sense electrical stimuli (Sutton et al., 2016). However, the entire body of *B. terrestris* is covered with these hairs and there is no reason to suggest that those on the head would be unique in their electroreceptive ability, and so it is plausible to suggest that hairs over the entire body surface of the bee might also be capable of electroreception. Because of this it is important to ensure that as much of the body surface as possible is uncovered so as to interfere with stimulus delivery as little as possible.

Another criterion that was important to consider when designing the restraint was comfort; efforts were made to minimise stress to the bee and therefore maximise the chance of bees giving normal behavioural responses. This is of particular significance in the context of PER experiments, as bumblebees are notorious for their poor performance in PER experiments, tending to become agitated and distracted. Several restraint designs were produced (see fig. 3.3), and the PER conditioning trials were repeated using each of the different designs in order to determine the effect of the harness on the performance of the bee and establish which design the bee performed best in.

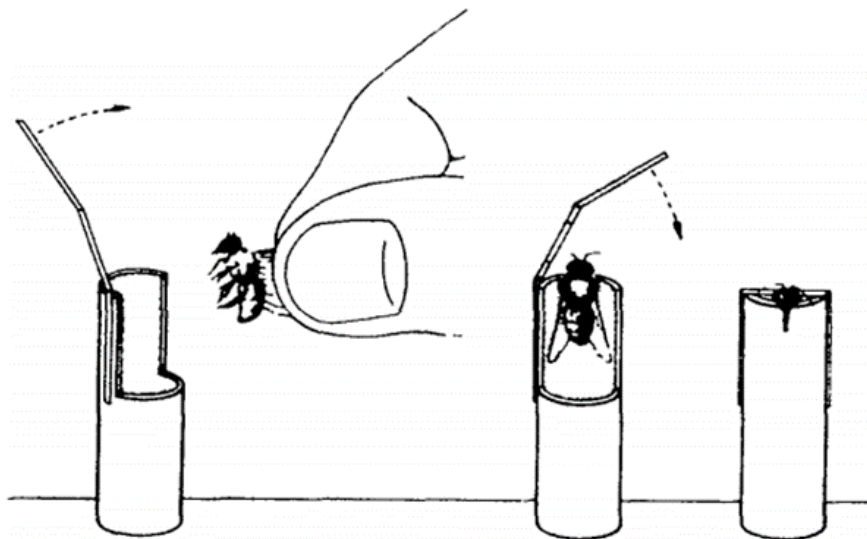

Figure 3.2 – Traditional restraint used in PER experiments. Reprinted from “Classical Conditioning of Proboscis Extension in Honeybees (*Apis mellifera*)”, by M. Bitterman, R. Menzel, A. Fietz and S. Schäfer, 1983, *Journal of Comparative Psychology*, 97(2), p. 108.

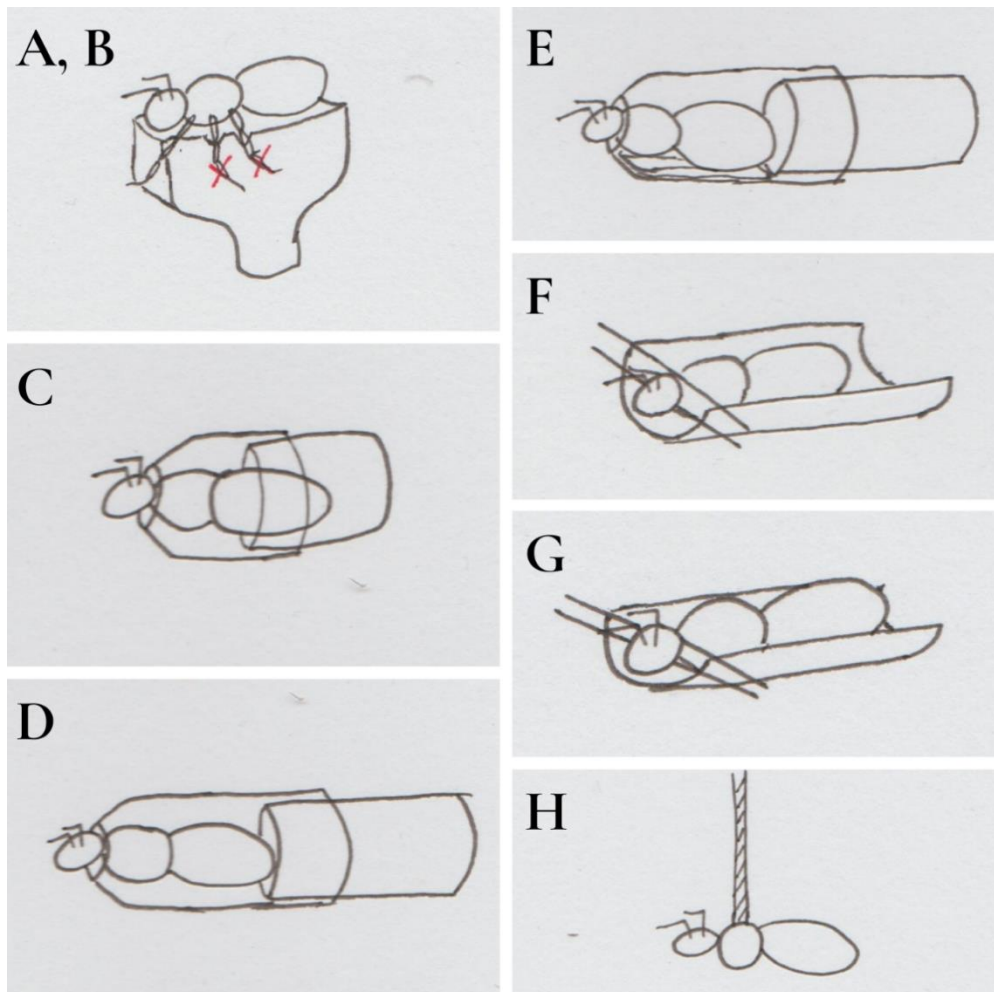

Figure 3.3 – Diagrams of each of the harnesses used to restrain bees during experimentation. Further information about the designs and materials used can be found in Appendix 1.

### 3.2.3 – Habituation-dishabituation paradigm

The term habituation refers to the progressive decline in an organism's response to repeated presentation of a stimulus. Habituation to a stimulus can be reversed either passively or actively; the former is known as spontaneous recovery and the latter, dishabituation (Byrne & Hawkins, 2015). Dishabituation occurs when the animal perceives a stimulus that is different to the habituation stimulus, triggering receptiveness to the original stimulus once more.

The phenomena of habituation and dishabituation can be used to test the sensitivity of an organism to a stimulus, as dishabituation will only occur if the non-habituated stimulus (test stimulus,  $t$ ) is perceived by the organism – and perceived as different from the habituation stimulus ( $h$ ). Habituation-dishabituation (H-D) experiments begin with the repeated presentation of  $h$  until habituation occurs, followed by presentation of  $t$ . Finally, the organism is re-presented with the initial stimulus which acts as a probe ( $p$ ); if the organism has been able to perceive  $t$  it will have been dishabituated from  $h$ , and will respond to  $p$  in the same way as it responded to  $h$  prior to habituation. This phenomenon is illustrated in figure 3.1.



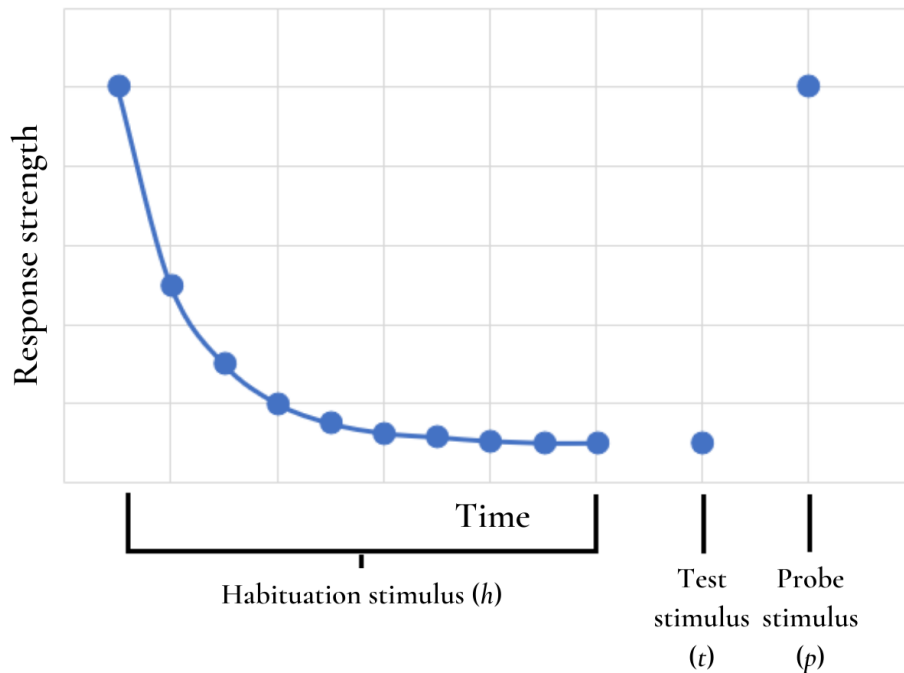

Figure 3.1 – Graph representing the habituation-dishabituation paradigm, showing the change in the strength of a behavioural response to a repeated stimulus before and after dishabituation.

The H-D paradigm is often used in human psychophysics, particularly with studies on infants as they are not able to verbally convey what they are experiencing (e.g. Brody et al., 1984; Kisilevsky & Muir, 1984). The paradigm has also been used extensively in studies on non-human mammals (e.g. Price et al., 2020; Root-Gutteridge et al., 2019), other vertebrates (e.g. Farrow et al., 2021; Mangiacotti et al., 2020; Messina et al., 2020), and invertebrates including insects (e.g. Agin et al., 2006; Corfas & Dudai, 1989), and it has been used at least once in bumblebees (Plowright et al., 2006).

When designing a habituation-dishabituation experiment, there are two alternative approaches that can be taken: unimodality and multimodality. With a unimodal design the habituation stimulus is of the same category as the test stimulus (e.g. both auditory stimuli), whereas in a multimodal approach the habituation and test stimuli act on different sensory systems, for example habituating to a tactile stimulus and dishabituating with an auditory stimulus, as seen in Kisilevsky & Muir, 1984. The former is particularly useful in determining whether an organism is able to detect an incremental change in the presented stimulus, such as a change in its strength or intensity. As the aim of this study is to identify the sensitivity of electrosensing in *Bombus terrestris*, both in terms of identifying the minimum stimulus perceptible and the spatial acuity, a unimodal approach was chosen initially; this would allow for direct comparison between different strengths of electric field, providing an indication of the sensitivity of the electric sense in *B. terrestris*.

### 3.2.3.1 – The habituation stimulus (*h*)

A key component of the H-D approach is a habituation stimulus, *h*, that is not only detectable by the study organism, but also elicits an observable response. Initially an electrical stimulus was explored for this use. Bees were presented with a biologically relevant electrical stimulus (30V) at a distance of 2cm for two seconds every twenty seconds, and were observed for a behavioural response (n=15). None of the bees responded to the stimulus with a consistent behaviour, and so the electrical stimulus was determined to be unsuitable for use as the habituation stimulus.

In order to maintain a unimodal approach another experimental procedure was examined for its potential to provide a standard and consistent behavioural response to the presentation of electric field. The Proboscis Extension Response, or PER is a widely used associative learning technique which involves bees learning to extend their proboscis in response to a certain stimulus which they have been trained to associate with a sugar reward (e.g. Bitterman et al., 1983). If bees were trained to associate an electrical stimulus with a sucrose reward, PER could be used during H-D experiments as *h*, allowing a unimodal approach to be taken.

While PER has been used in combination with the H-D paradigm before (Bicker & Hähnlein, 1994; Haupt & Klemm, 2005), an electrical stimulus has never been used in this setting. Additionally, bumblebees are notoriously difficult to train with PER as they have a tendency to become disturbed and distracted. Therefore, prior to trialling PER with an electrical stimulus, tests were carried out with an olfactory stimulus to provide proof of concept that this procedure will be suitable for use in the H-D experiments.

### 3.2.3.2 – PER olfactory conditioning trials

Bees were trained to associate an odour (conditioned stimulus, CS) with a sucrose reward (unconditioned stimulus, US). Lavender oil was chosen as the CS due to its strong odour and availability; the US was a solution of 30% sucrose. This concentration was chosen as lower concentrations may not be rewarding enough to provide appetitive motivation, whereas high concentrations are more viscous and can be difficult for the bee to consume through the proboscis (Matsumoto et al., 2012).

After the training period, the bee's response to presentation of the CS in the absence of the US will reveal whether the association has been learnt; if successful, the bee's proboscis will extend.

The aims of the PER trials were twofold: to establish whether PER is likely to be a suitable habituation stimulus for use in the H-D experiments, and to determine which of the proposed harness designs is most appropriate. These goals were achieved by repeating the trial using each of the eight designs.

Prototypes of eight harnesses were constructed (see fig 3.3 and Appendix 1). In the case of designs A and B, several different sizes were made to ensure the bee could be held comfortably regardless of individual

	Time into trial (seconds)	5s	5s
Training phase	120	CS	CS + US
	240	CS	CS + US
	360	CS	CS + US
	480	CS	CS + US
	600	CS	CS + US
	720	CS	CS + US
	840	CS	CS + US
	960	CS	CS + US
	1080	CS	CS + US
	1200	CS	CS + US
	1320	Air	Air
	1440	Air	Air
	1560	Air	Air
	1680	CS	CS

Table 3.1 – Schedule of training and testing of PER responses. The CS is a puff off air from a pipette containing filter paper soaked in lavender oil and the US is a reward of 30% sucrose solution.

variation in size. Bees were mounted in the harness and fed to satiation with 30% sucrose solution. They were kept overnight in a dark room allowing them to acclimatise to being restrained and ensuring they were sufficiently food-motivated during the experiment (Matsumoto et al., 2012).

During the PER trials, bees were placed in harnesses and fixed in place using modelling wax. A 2.5x2mm piece of filter paper soaked in lavender essential oil was folded and placed inside the bulb of a 3ml graduated pipette. The pipette was then positioned so that the tip was 1cm from the bee's head. An aquarium air pump was used to force air flow and ensure the odour stimulus was removed when not being intentionally applied. Bees were placed in situ and allowed to acclimatise to new surroundings for 120 seconds.

The training schedule used can be seen in table 3.1. After the initial training phase, the pipette containing the CS was replaced with an identical empty pipette and bees were exposed to puffs of air from this three times for 10 seconds each with intervals of 110 seconds. After this, the CS pipette was returned and the CS was presented for 10 seconds without reward. If the bee has been able to learn to associate the CS with a sucrose reward this would be demonstrated at this point by extension of the proboscis and the trial would be deemed a success. After experimentation, bees were marked with a dot of nail varnish on the thorax before being returned to their colony to ensure no bee was used more than once.

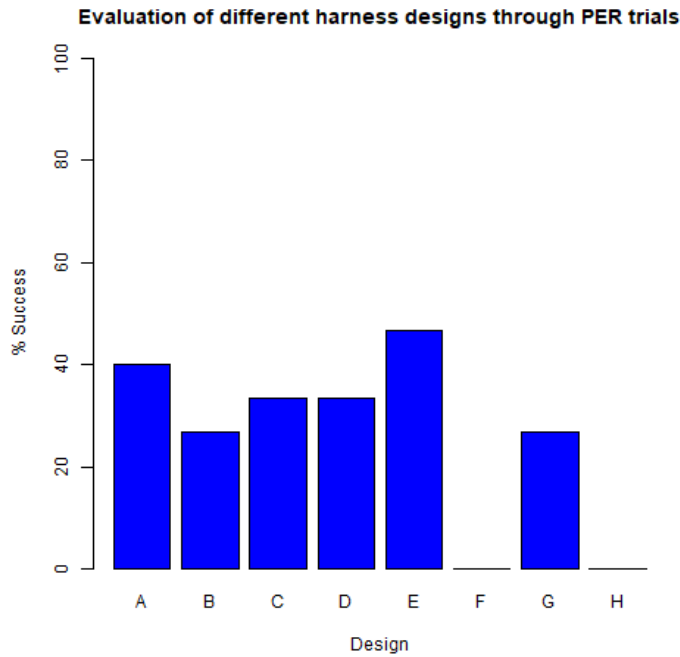

Figure 3.4 -Bar graph showing the percentage of successful PER trials for bees restrained in each of the eight harness designs.

### 3.2.3.3 – Results of PER trials

PER trials were carried out with 15 bees per harness design. The percentage of successful trials was compared for each of the harness designs, and the data were analysed using a one-way ANOVA followed by a Tukey HSD test.

The bees performed poorly in all of the olfactory learning tests, with no harness design achieving higher than a 50% success rate. In the trials of designs A and E, bees performed significantly better than those of designs F and H, both of which achieved 0% success (see fig. 3.4). Upon removal of the two worst performing designs, there was no significant difference between the performance rate of bees in any harness, suggesting that any of these six remaining harnesses would be suitable for use in later experiments. As designs A and B leave the highest surface area uncovered, these two designs may be more suitable for exploring sensitivity to electrical stimuli; because of its relatively high success rate, harness A was chosen for use in future experimentation.

Due to the low success rate of these trials, the decision was made to move away from PER and explore an alternative habituation stimulus.

### 3.2.3.4 – Determining the habituation stimulus (*h*)

Due to the lack of observable response of bees to electrical stimuli and the failure of the PER approach, it was necessary to change from a unimodal to a multimodal approach, using a habituation stimulus acting on a different sensory system than the electrical test stimulus. Although this no longer allows responses to

incremental changes in the electrical stimulus to be directly compared, it is still possible to use the H-D paradigm to explore the spatial limitations of the electric sense of bees.

Restrained bees were observed to respond to a tactile stimulus of a single strand from a paintbrush touching the antennal flagellum and the thorax. A paintbrush was chosen as the bristles have a similar triboelectric value to bees and therefore are unlikely to affect the charge of the bee. When the flagellum of the left antenna was touched with the paintbrush, the right antenna twitched at the pedicel in 100% of bees (n=5). The same response was seen in 80% of bees upon touching of the paintbrush to the thorax (n=5).

Bees were taken to have habituated when they showed no response to presentation of the stimulus twice in a row after having responded at least twice in a row beforehand; dishabituation was taken to have occurred when the antennal twitch response returned following the presentation of an auditory stimulus (a clap). When the antennal stimulus was repeatedly presented, 60% of bees habituated to the stimulus and were able to be dishabituated by the auditory stimulus; for thorax stimulation this figure was 40% (fig. 3.6). However, 40% of bees in both treatments were still showing a positive response after 20 trials, at which point the recording ceased. It is therefore possible that these bees may have habituated to the stimulus given more repeated presentations. Additionally, due to the small sample size (n=5 for both treatments) individual variation in sensitivity could account for a large amount of the variation in data.

There is no significant difference between the success rates of habituation and dishabituation between the two treatments (paired t-test,  $p > 0.05$ ) suggesting that either could be used as *b* in future experimentation.

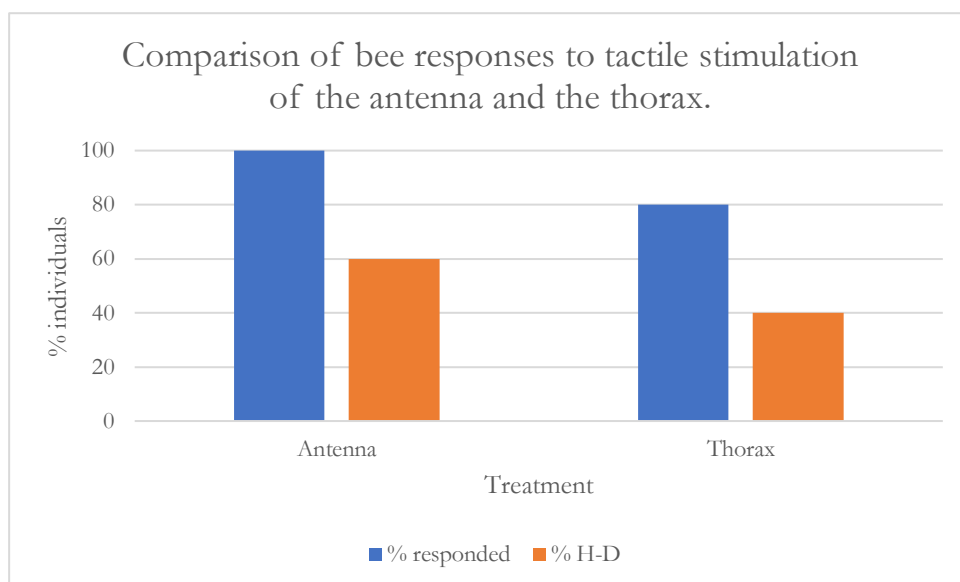

Figure 3.6 – Percentage of bees that responded with antennal twitches (blue bars) and successfully habituated and dishabituated (orange bars), compared for tactile stimulation of the antenna and the thorax. There is no significant difference between either responses to the two treatments.

### 3.3 – Exploring distance

Using a tactile *h*, a procedure was designed to explore the effect of distance from a charged object on the electroreceptive ability of bees.

The objectives of this experiment are a) to determine the maximum distance a bee can be from a charged object and still perceive the object's electric field, and b) to examine the precision with which bees are able to differentiate between two identical charged objects at different distances.

To deliver the electrical stimuli to the bee, a circuit was created which linked a voltage function generator with amplitude control to a spherical probe which was placed in 2cm front of the bee. The charge of this probe could be manipulated using the voltage generator and could be turned on or off by a button switch in the circuit. The circuit also contained a voltmeter to enable constant monitoring of the voltage.

Another spherical probe was earthed and placed opposite the charged probe (behind the bee) to concentrate the electric field. Prior to experimentation, the bee should be charged by rubbing a Perspex rod along the body, as this will increase the potential difference between the bee and the probe, mirroring the natural state and allowing bees to better perceive electrical information (Dacke et al., 2013; Sutton et al., 2016).

When performing habituation-dishabituation experiments it is important to exclude any external stimuli as much as possible as these may cause bees to dishabituate or even fail to habituate. Therefore, the experiments were carried out inside a sensory isolation box consisting of a cardboard box lined with green card to simulate vegetation (fig. 3.5; Dyer et al., 2007). Card was chosen because of its high electrical resistivity meaning it would not interfere with the electric field between the bee and the charged probe.

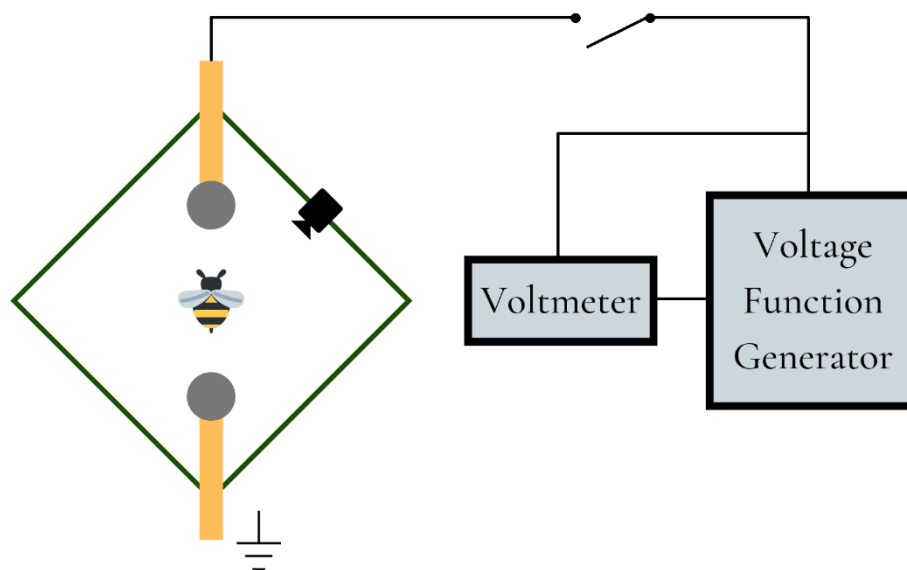

Figure 3.5 – Diagram of experimental setup. The bee is held within the sensory isolation box between two electrodes, one charged and one earthed. There is a camera within the wall of the box to allow real-time observations of the bees' reactions to stimuli.

Another measure taken to minimise disturbance to the bee was the decision to use stimulus charge (voltage) as a proxy for distance. According to the inverse Square law, the magnitude of an electric field ( $E$ ) is inversely proportional to the square of the distance from the source ( $r$ ; equation 3.1). As the magnitude of an electric field is equal to the charge ( $Q$ ) multiplied by the electrostatic constant ( $k = 8.99 \times 10^9$ ) divided by  $r^2$ , it is possible to manipulate the current rather than the distance and produce the same effect on the electric field (equation 3.2).

$$E \propto \frac{1}{r^2}$$

(Equation 3.1)

$$E = \frac{kQ}{r^2}$$

(Equation 3.2)

Therefore, by eliminating the need to move the bee or the charged probe during the experiment, perturbations that may cause the bee to dishabituate were kept to a minimum. However, it is not only field strength that changes with distance, but also the field geometry, so while this experiment will provide an indication of electrosensitivity in *Bombus terrestris*, it will not be able to account for variations in field geometry.

Further work is now needed to use this procedure to explore the range of the electroreceptive ability in *B. terrestris*. A variety of amplitudes should be used as the test stimulus during habituation-dishabituation experiments, and these should be provided at both resonant and non-resonant frequencies to determine whether this has any effect on bees' ability to perceive the stimulus (Sutton et al., 2016). As a multimodal approach to the habituation-dishabituation experiments was taken, it may be difficult to determine whether bees are able to distinguish between two different electrical stimuli, as this approach only tests for bees response to one electrical stimulus at a time rather than comparing two stimuli simultaneously. To explore the spatial acuity of electrosensing in *B. terrestris*, it may therefore be necessary to re-examine the bees' responses to electrical stimuli using video tracking technology to monitor whether the bees show any response to the stimuli, rather than relying on the human eye.

### 3.4 – Exploring direction

Originally the intention was to use an adaptation of the procedure described above to determine whether bees are able to infer directional information from electrical stimulation. The adapted setup includes a circle of spherical probes equidistant from the mounted bee which could be used to deliver electrical stimuli from different directions relative to the orientation of the bee (fig. 3.7). The aim would be to habituate the bee to a stimulus coming from one probe and use the same stimulus from a different probe as the dishabituation stimulus. However, this design is based on a unimodal approach to the habituation-

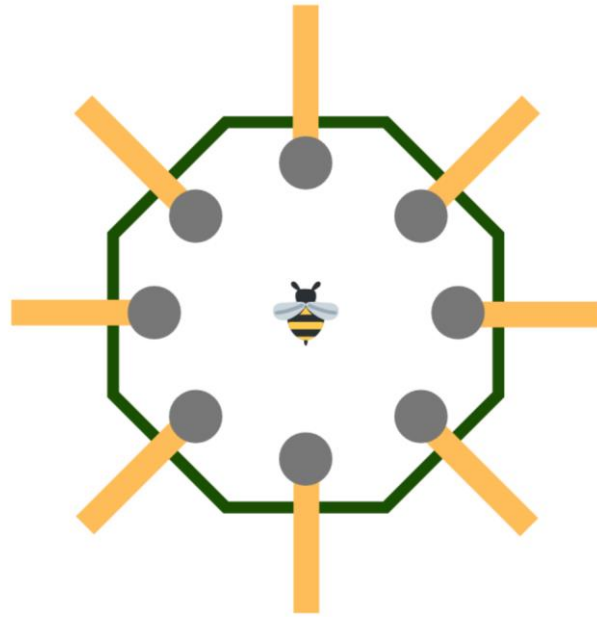

Figure 3.7 – Proposed experimental setup to test directional electrosensing in *B. terrestris*.

dishabituation experiments, and so could only be carried out if a physical response to electrical stimulation was observed or learned.

### 3.5 – Conclusion

Preliminary results based on an auditory test stimulus suggest that the procedure outlined above may be able to be used to shed light on the sensitivity threshold of the electric sense of *Bombus terrestris*, and could potentially be used to test the same thing in other species. The next stage in using this procedure is to explore dishabituation using electrical stimuli and to revisit the possibility of using an electrical signal as the habituation stimulus to enable examination of the sensitivity and resolution of electric field perception in bees.



# Chapter 4: Discussion

## 4.1 – Introduction

*Bombus terrestris* is an important pollinator, both commercially and ecologically (Ceuppens et al., 2015; Goulson, 2010; van den Eijnde et al., 1991). Research into the biology of this species is useful for understanding the nuances of pollination interactions, and can often inform approaches to agricultural and horticultural practices. Additionally, as a model organism for scientific research, information known about the buff-tailed bumblebee can be reviewed and applied to other insect systems which are less well understood (Ayasse & Jarau, 2014).

Although *B. terrestris* populations seem to be succeeding at present, many other bee species are in decline (Banaszak-Cibicka & Żmihorski, 2012; Hallmann et al., 2017; Rader et al., 2014). Because of the important role bees play in pollination, this decline could be disastrous for the environment and for food security, as many plant species are dependent upon these insects for their reproduction (Goulson, 2010; Goulson, 2019). Therefore it is important to explore different aspects of the biology and ecology of pollinators in order to develop an understanding of their interactions with the environment and the ways in which human activities can affect them.

As senses shape the way an organism interacts with the world, the discovery of electroreception as a novel sensory modality provides a fresh perspective on the behaviours, interactions and relationships of bees with their environment, and further research into this sense may provide useful insights into the lives of these extraordinary organisms.

### 4.1.1 – Signals or cues?

The terms ‘signal’ and ‘cue’ both refer to a trait, process or behaviour from which an organism is able to gain information. However, these two terms are not synonymous, with the difference lying in the evolutionary origin of the trait: signals evolve specifically for the purpose of conveying information, whether this be to conspecifics, such as pheromones, or to other species, as seems to be the case with many floral volatiles. Conversely, cues are traits which provide information to an individual, but which evolved in response to another, unrelated selection pressure. For example, in flowers, the petals and sepals provide protection for the reproductive structures; when these structures are larger, such as in many pistillate flowers, the petals and sepals are in turn larger (Essenberg, 2021). While flower size is known to influence bees’ foraging decisions (Spaethe et al., 2001), this information can be considered a cue as it appears to have evolved for a function other than pollinator attraction.

When considering whether an information source is more likely to be a signal or a cue, it is important to reflect upon the selection pressures under which it evolved. Evolution does not occur in isolation, and at any one time a system is facing multiple selection pressures which can be concurrent, favouring selection in the same direction, or antagonistic, with conflicting optima. In the case of the latter, the result of

evolution depends on the relative strength of the selection pressures in terms of how much each impacts upon the fitness of the individual, often resulting in a trade-off which is not optimal with respect to either selection pressure but causes the largest overall increase in fitness.

Signals are traits where the primary selection pressure has been the effective transmission of information, as is the case in many animal communication behaviours such as the honeybee's waggle dance. Signals can also be tied to coevolutionary dynamics, as is thought to be the case in certain plant-pollinator interactions, whereby the signal sender evolves to make their signal clearer for the intended party, and the signal receiver evolves to provide mutual benefit to the sender, such as through pollination and flower constancy. This can result in highly specialised systems, whereby two species are reliant upon one another, or more generalist systems where signals are produced for a wider group of species, all of which provide a similar benefit to the sender (Schiestl & Johnson, 2013; Shimizu et al., 2014).

## **4.2 – Function of aerial electroreception in *Bombus terrestris***

Bees have been shown to be able to perceive electrical stimuli in their environment, and to be able to use this information to inform foraging decisions in a lab setting. However, what is unclear is how electrical information is used to inform bee behaviour in a natural setting. Here I explore the potential functions of electric field perception in the behaviour and ecology of *B. terrestris* and elucidate how electrical information may shape the way bumblebees experience the world.

### **4.2.1 – Foraging**

The initial experiments exploring electroreception in *Bombus terrestris* focussed on foraging behaviour (Clarke et al., 2013). Bees are able to quickly learn to associate stimuli of many kinds with sucrose rewards, and foraging-based studies are able to provide a lot of information about their sensory systems and learning ability, and how different stimuli are perceived. However, though they can be trained to use electrical stimuli as a foraging cue, this does not necessarily mean they do so in a natural environment.

To clarify whether electrical information affects bumblebees' perception of flowers and their choice of forage, it is important to recognise the different ways in which electrical information may provide cues and signals about the foraging environment.

#### **4.2.1.1 – Floral cues**

Entomophilous plants – those which rely on insects for pollination – produce a variety of signals (known as floral cues) to attract pollinators. These signals exploit a range of insect sensory modalities, including vision (e.g. colour, shape and nectar guides), olfaction (floral scent bouquets) and temperature sensing. It is in the best interest of the plant to be as attractive to insects as possible, so it makes sense for flowers to

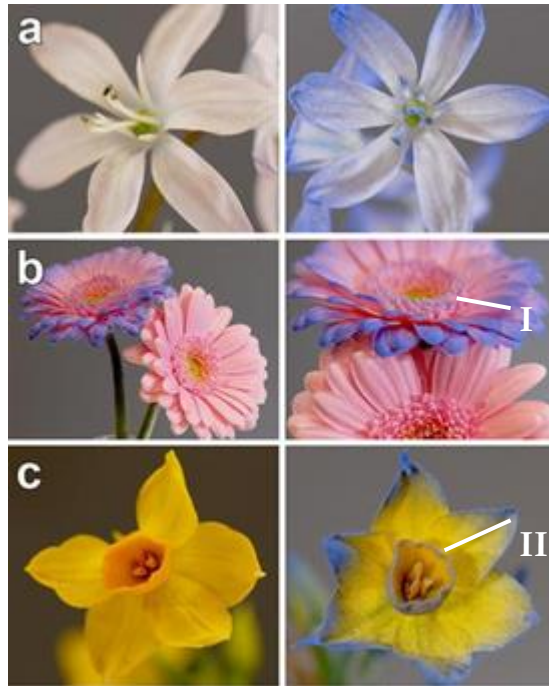

Figure 4.1 – “Visualisation of floral electric fields using electrostatic dusting. Flowers are shown before (left) and after (right) dusting... Genera shown are a) *Lilium*, b) *Gerbera* [and] c) *Narcissus*.” Adapted from “The bee, the flower, and the electric field: electric ecology and aerial electroreception”, by D. Clarke, E. Morley and D. Robert, 2017, *Journal of Comparative Physiology A*, 203(9), page 743.

have evolved to provide a large amount sensory information, addressing all sensory modalities of their pollinators.

The electrical ‘footprint’ of an object is affected by its shape, which influences charge distribution over the object’s surface. By altering its shape, a flower can alter its electrical signature, and therefore potentially alter the information it conveys to pollinators. Figure 4.1, shows a physical representation of the charge distribution on three different flower species; charge accumulates on sharp lines and pointed structures, including the edges of the petals and the tips of the stamen and pistil.

When considering the possibility that flowers have evolved to produce a specific electrical signal, it is important to consider what information the plant could be trying to convey to its insect pollinators. Could it be that bees have an innate sensory bias for certain geometries of electric field that plants have adapted to exploit? Or perhaps the presence of different electrical cues reinforces learning of specific flowers and promotes floral constancy? Could the electrical footprint even act as a kind of nectar or pollen guide to decrease bees handling time of flowers? It is also possible that the shape of flowers (and therefore their electrical footprints) have evolved in response to different selection pressures, and that any information used by the bee is a cue rather than a signal.

To explore this question further, it is first important to explore what is already known about floral cues, and the specific behaviours they encourage. There are several stages which make up the majority of nectar

foraging in *Bombus terrestris*: firstly, the bee must observe a flower and approach from a distance, a behaviour which has been linked to visual information, specifically the colour of the corolla and its contrast against the background (Lunau, 1992; Spaethe et al., 2001). Secondly, the bee must examine the flower at close range, often touching the flower with its antennae whilst still in flight; again, this behaviour has been linked to visual cues, with bees often orienting towards the regions of the flower with the highest spectral purity (Lunau, 1992). Thirdly, if the flower is deemed acceptable thus far, the bee must land. Both visual and olfactory stimuli are important in initiating this behaviour, and tactile and gustatory stimuli have also been shown to increase landing behaviour (Lunau, 1992; Wilmsen et al., 2017). Finally, nectar collection behaviours such as extending the proboscis occur. As with landing, several sensory modalities including vision, olfaction and gustation are thought to be important for initiating this behaviour (Wilmsen et al., 2017).

The role of different sensory modalities as behavioural prompts in foraging has been investigated by studies in which the sensory properties of artificial flowers were altered and bees' behaviour recorded (Lunau, 1992; Wilmsen et al., 2017). An interesting concept for further research would be to design similar experiments in which the innate preferences of flower-naïve bumblebees towards varying floral electric fields is tested. Bees should be provided with artificial flowers with a variety of different sensory characteristics, including the presence or absence of electrical stimuli with varying geometries, and their behaviour observed to determine whether certain characteristics or combinations of characteristics elicit the aforementioned foraging behaviours. It is important that naïve bees should be used for this experiment so as to remove the effect of learnt foraging cues on the behaviour the bees exhibit.

If an innate preference for certain electric field geometries is revealed, this would indicate that electrical stimuli do impact the foraging decisions of bees. Additionally, it could have implications for the evolution of floral shape; many floral characteristics have evolved in response to the pre-existing sensory biases of their pollinators, and the presence of such a bias for electric field geometries could indicate pollinator-driven evolution of floral shape, and therefore floral electric field geometry (L. Chittka, 1996; Ramirez et al., 2011).

It may seem unnecessary to evolve such a variety of different approaches to solve a single problem – that of pollinator attraction, but complex multi-modal floral signalling is common and widespread. Various hypotheses have been proposed to explain signal complexity; firstly, one hypothesis suggests that multiple signals allow a single plant to attract many different pollinator species, therefore maximising pollination (Leonard et al., 2011). However, if this were the case, those plants with very specific pollinator relationships should have relatively simple floral signals as there is not the need to attract many different organisms, and floral signals are costly to produce. Even plants which rely on a single or a small group of pollinators have developed a variety of different floral cues (Ramírez, 1991; Ramirez et al., 2011),

suggesting that, though it may be a factor in signal complexity, this hypothesis is definitely not the complete picture.

Several other hypotheses have focussed on the effect of multi-modal signals on pollinator learning and flower recognition. It has been demonstrated that multi-modal floral signals facilitate learning and memory in bees (Balamurali et al., 2015; Clarke et al., 2013; Katzenberger et al., 2013). How this occurs is still unknown; suggestions are split between viewing the different sensory modalities as independent or as interacting. In the former view, it is suggested that processing of cues targeting different sensory modalities is unconnected, and that when more than one cue is present, this simply increases the amount of information available, thereby improving certainty (Leonard et al., 2011). Conversely, when viewing different signal modalities as having an impact on one another, the interaction between stimuli is thought to provide a context for learning and memory that may trigger recall or use of different modalities, or even out-compete other signals by monopolising access to the working memory (Harrap et al., 2019; Leonard et al., 2011).

Support for the idea of cross-modal signal interactions is demonstrated in bees' ability to transfer learning between sensory modalities. Bees presented with odour compounds displayed in a spatial pattern with different concentrations in different areas are able to learn this pattern and apply it when foraging using only visual cues (Lawson et al., 2018). After learning the scent distribution, bees will forage preferentially on flowers exhibiting a corresponding visual pattern, indicating that visual and olfactory processing are integrated in the bee's brain, both providing spatial information. Interestingly, a similar experiment testing cross-modal learning using vision and temperature sensing revealed bees were unable to make a connection between information gained from these two modalities, suggesting perhaps that there are differences in the ways temperature information is processed and/or stored compared to visual and olfactory information (Harrap et al., 2019).

While it is known that the presence of an electrical stimulus enhances learning of a visual cue (Clarke et al., 2013), it is not known how this enhancement occurs. Bees are able to discriminate between different spatial patterns of electric fields (Clarke et al., 2013), so it is reasonable to speculate that this spatial information may interact with other modalities as does visual and olfactory spatial information (Lawson et al., 2018). Examining this further by testing visual or scent pattern recognition in bees trained to recognise electric field shapes would provide a notion of whether electrical cues interact with those in other sensory modalities, or whether, as appears to be the case with temperature cues, the processing of electrical information is independent of certain other sensory modalities.

Another hypothesis explaining the complexity of floral signals relates to variability in the environment; changes in environmental conditions such as light intensity, wind speed and direction and humidity may have effects on the salience of different floral cues (Lawson et al., 2017). In the case of one floral signal being obscured by environmental noise, other signals may act as a 'backup'. This hypothesis has been

investigated in *B. terrestris*. Lawson et al (2017) revealed that colour cues act as an effective backup when scent cues were obscured by chemical interference and high wind speeds. Interestingly, chemical interference was also found to hinder foraging using purely visual stimuli, suggesting there may be an integration of sensory information.

This backup effect has been demonstrated in other insects; ball-rolling dung beetles travel in straight lines to maximise the efficiency of their movement in terms of distance moved per unit time. They orient themselves by using celestial cues such as the position of the sun or milky way in the sky (Dacke et al., 2013, 2019). However, these cues are not always available; for example, when the sun is at its zenith, it provides no directional information, and on cloudy nights when the milky way isn't visible, this too is removed as a potential orientation cue. In these instances, the beetles are able to integrate information about wind direction to act as a secondary cue (Dacke et al., 2019). Directional information is therefore obtained from multiple sensory modalities, and the order in which these cues are used is weighted.

The order that sensory inputs are utilised could be based on the relative importance or perhaps the relative reliability of different cue types, as well as their availability. When considering the electrical footprint of a flower as a potential floral cue, we know that it is not a necessity for foraging behaviour as bees are able to perform without this information (Clarke et al., 2013). However, it could be that electrical cues become more important in situations where other information is scarce, such as in low light conditions. Equally, perhaps other cues gain a higher weighting when electrical information is obscured, such as may occur in poor weather conditions.

#### **4.2.1.2 – Nectar guides**

Another approach to elucidate the potential information gained through floral electric fields is to examine the variations in charge density and distribution on different flowers, and to examine whether there are any differences between that of insect-pollinated and non-insect-pollinated plants. Observing figure 4.1, a higher charge density can be seen around the edges of flowers; this could aid in the identification of flowers during the 'approach from a distance' and flower inspection phases of foraging. Additionally, some flowers have structures surrounding the area where nectar and pollen is found, such as the trans-florets of the *Gerbera* (fig. 4.1 B: I) and the corona of the *Narvissus* (fig. 4.1 C: II). These structures are shown to have higher charge density than the surrounding petals and could act as a nectar or pollen guide. Nectar guides have been shown to be beneficial to pollinating insects by decreasing handling time of flowers causing a reduction in energy expended while foraging, and this in turn benefits the plant by maximising visitation rates of the flowers (Leonard & Papaj, 2011).

Although it seems that the *Lilium* flower (fig. 4.1A) lacks electrical nectar guides, there are areas of increased charge density in the centre of the flower; the stamen and pistil show a high charge density at their tips, a feature which could attract bees to this area of the flower, increasing their chance of

interacting with pollen and therefore pollinating the plant. It is also possible that this feature has evolved to maximise pollination in another way; electrostatic forces aid in the transfer of pollen between bee and flower, and vice versa (Armbruster, 2001; Corbet et al., 1982; Vaknin et al., 2000).

#### **4.2.1.3 – Indication of nectar availability**

Even if plants have not evolved to produce floral electric signals, electrical information may still be able to provide information relevant to foraging bees. As discussed in Chapter 2, bumblebees have been found to leave behind chemicals on surfaces they move across which are able to act as cues for conspecifics and heterospecifics (Ayasse & Jarau, 2014; Jarau et al., 2012). When foraging, bees perceive the strength of these scent marks and use this as an indication of floral reward. Higher concentrations of these chemicals on a petals surface could indicate certain flowers have a longer handling time, thereby reducing the net reward for visiting it, or they could indicate that the flower has been recently visited, thereby indicating nectaries are likely to be depleted. Both provide information which reduces time wastage and therefore maximises foraging potential.

It is possible that electrical stimuli may provide information about how recently a flower has been visited by an insect, and therefore about the likely availability of nectar therein. Most flying insects have a positive charge, and when they come into contact with an earthed object, like a flower, some of this charge is transferred between the two objects, causing the floral electric potential to increase (Clarke et al., 2013). This change happens instantaneously, beginning even before contact has been made between the bee and the flower, and it takes around 100 seconds for the floral electric potential to return to its original level (see fig. 4.2). Although on the shorter end of the scale, this time correlates with the amount of time taken by some plant species to refill nectaries after insect visitation (Goulson, 2010; Kadmon & Shmida, 1992; Luo et al., 2014). Therefore, it is possible that the electric potential of a flower could be used as a cue indicating the likely presence or absence of nectar.

While electric potential changes over a timescale of seconds to minutes, scent marks change over longer timescales and can last for up to 24 hours (Pearce et al., 2017). Considering the effectiveness of multimodal cues in providing information to pollinating insects, it is possible that bumblebees use a combination of electric potential and scent marks to determine how recently a flower has been visited by another pollinator, and therefore whether there is likely to be nectar available.



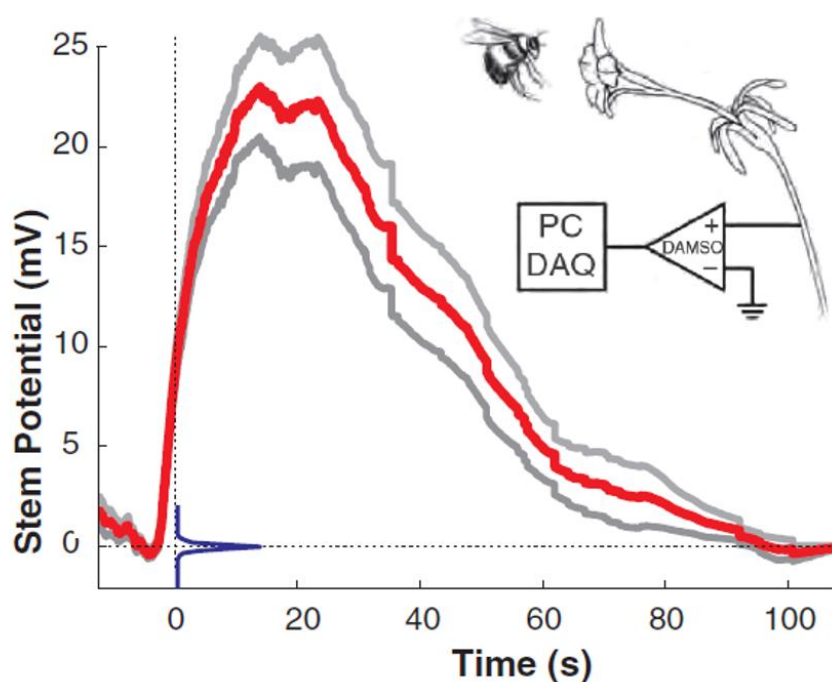

Figure 4.2 – Change in electric potential of a petunia stem over the course of visitation by a bumblebee, *Bombus terrestris*. Adapted from “Detection and Learning of Floral Electric Fields by Bumblebees”, by D. Clarke, H. Whitney, G. Sutton and D. Robert, 2013, *Science*, 340(6128), page 67.

#### 4.2.2 – Intraspecific communication

Although much of the focus of research on electroreception in *Bombus terrestris* thus far has been into its potential as a mechanism for locating and assessing flowers and floral rewards, it is important to consider the other possible functions this sensory modality could perform.

As primitively eusocial insects, buff-tailed bumblebees need to communicate with nestmates to function as a colony and maintain order in the nest. Odours such as pheromones play an important role in communication – seemingly more so than visual stimuli; this could be due to the majority of social interactions taking place within the nest where there are low light levels. Electrical information could be especially useful in situations where other sensory input is lacking, so it is possible that interactions taking place within the nest make use of electrical stimuli in addition to olfactory cues.

Honeybees, known for their waggle dance (Frisch, 1948), have been shown to respond to the electrical signals produced by dancing bees, and therefore electrical signalling has been hypothesised to play a role in forager recruitment (Greggers et al., 2013). Although they do not dance as honeybees do, bumblebees do have a specific forager recruitment behaviour which involves ‘excited runs’ through the nest (Goulson, 2010). It has been suggested that this behaviour provides a vibrational signal to other bees (Hunt & Richard, 2013), and perhaps the electrical signature of this movement also provides information to nest mates.

Many other behaviours, including queen-worker conflicts and rearing of young take place exclusively within the confines of the nest where visual information is scarce, so it is possible that electrical information plays a role in informing these.

Another important role of intraspecific communication in *B. terrestris* is in mating. Males of this species partake in a behaviour known as patrolling, where they repeatedly fly a circuit along which many landmarks have been scent marked with the male sex pheromones. Virgin queens linger at these landmarks and await the arrival of males. While this behaviour is mainly controlled by pheromones (Ayasse & Jarau, 2014), it is possible that electrical information is used as a backup sensory modality in the instance of disruption of the olfactory signal. Additionally, it is possible that information indicating fitness of the male is contained within his electrical footprint, perhaps linked to his wingbeat frequency or the condition of the hairs on his body; if this is the case, virgin queens could potentially make use of this information to inform their mate choice.

Of course, this is just speculation at this stage; in order to evaluate whether any of these behaviours do in fact contain electrical signals, it is necessary first to determine the electrical profile produced by each of these behaviours. Playback experiments may then help to elucidate whether there is any signal or cue in the electrical signature of bee social behaviour, or whether it is simply noise that does not contain any relevant or functional information.

#### **4.2.3 – Heterospecific communication**

Although seemingly not as integral to their biology as intraspecific communication, bumblebees do occasionally communicate with heterospecifics. As different species do not necessarily share the same means of communication, interspecific communication can be separated into two channels: broadcasting information to and receiving information from heterospecifics. The latter could be linked to foraging cues; *Bombus terrestris* is known to respond to floral scent marking of both conspecifics and heterospecifics (Goulson, 2010; Saleh et al., 2007), and the same could possibly be said of electrostatic cues. Indeed, there is no species-specificity involved in the change in floral electric potential upon contact with a pollinating insect, so if bumblebees are able to make use of this change as a foraging cue, it is likely that they will respond to flowers visited by any pollinator species.

The broadcasting of information to heterospecifics predominantly takes the form of warning signals to deter predators. Although in possession of a venomous sting, bumblebees seldom use their sting due to the high metabolic cost of producing venom. Instead, they perform a number of warning behaviours in response to a perceived threat. These warning signals include raising of a leg (Varnon et al., 2021) and producing a hissing sound through vibration of the wings (Kirchner & Röschard, 1999; Rowe & Guilford, 1999; Siddall & Marples, 2011).

Whether the electrical signatures of either or both of these behaviours could convey a deterrent effect depends on the recipient and whether it is capable of electroreception. Domestic chicks (*Gallus gallus domesticus*), have been shown to be indifferent to the hissing behaviour of *B. terrestris*, except for a slight change in colour preference of food (Rowe & Guilford, 1999; Siddall & Marples, 2011). However, this warning is apparently effective against some avian predators as there is evidence that this signal can cause birds to abandon established nests (Jablonski et al., 2013). In the former, the hissing signal provided to the chicks was solely acoustic, whereas the latter signal, recorded from observations of wild behaviour, would have had an electrical component too. It is therefore possible that the electrical information had an impact on perception of the signal; however, there is as yet no evidence that vertebrates are able to sense electrostatic stimuli and it is likely that it was merely a response to the acoustic stimulation.

#### 4.2.4 – Predator avoidance

If bees are able to sense the electrical signature of approaching organisms, they may be able to use this information as a method of avoiding predation. The primary predators of bumblebees are birds, mammals such as badgers, and spiders (Goulson, 2010). Badgers prey on bumblebee colonies by digging them up and consuming them, and so bees would not be able to sense the approach of a badger above ground using electrosensing. However, it is possible that they could sense a bird in flight by its electrical footprint and use this information to trigger evasive behaviour.



Figure 4.3 – *Misumena vatia*, a cryptic predator of bumblebees with its prey, a yellow-faced bumblebee (*Bombus vosnesenskii*). Printed with permission from Dean, N. (2015). *Bombus vosnesenskii* (Yellow-faced Bumble Bee) - *Misumena vatia* ♀ (Flower Crab Spider). [Photograph]. South Everett, USA. [www.flickr.com/photos/44691276@N06/18945175381/in/photostream/](http://www.flickr.com/photos/44691276@N06/18945175381/in/photostream/)

A significant predator of bumblebees is the crab spider, *Misumena vatia*. This spider is an ambush predator, remaining still and camouflaged on flowers and attacking foraging bees (Morse, 1983, 1986). Studies on the response of *B. terrestris* to the presence of *M. vatia* have revealed that, despite its camouflage colouration, experienced bees are able to learn to recognise the presence of crab spiders and avoid dangerous flowers accordingly (Ings et al., 2012). Shape was revealed to be important in this context: bees avoided flowers with 3D models of spiders but were indifferent to those with circular models with the same colour camouflage. The study speculated that the bees form an achromatic visual ‘search image’ which they use to examine flowers for the presence of spiders. However, as bees are able to distinguish the geometry of electric fields, the presence of the spider on the surface of a flower may be detectable using the electric sense. In particular, the long, sharp legs of the spider are likely to have a high charge density, and so cause a marked difference in the geometry of the floral electric field. It is therefore possible that bees could use their electric sense to detect and avoid crab spiders.

However, if bees are able to sense the presence of a spider this way, surely they would avoid foraging on flowers with spiders altogether. Ings et al. observed that only experienced bees learnt to avoid flowers with model spiders; perhaps, an encounter with a spider triggers an association between the particular electrical signature sensed and the threat of danger? If this is the case, it would seem that the use of electrical information in the context of predator avoidance is not an innate ability, but a connection that is made with the sensory characteristics of the bee’s surroundings when encountering a threat.

### **4.3 – Application of the methodology**

Bearing in mind the potential functions of electroreception identified above, the methodology outlined in Chapter 3 could provide insight into the ways in which electrical information is perceived by *Bombus terrestris*, and therefore indicate which functions are most likely.

#### **4.3.1 - Distance**

The first part of the procedure was designed to examine the sensitivity of electroreception in *B. terrestris*. Because of the nature of the relationship between charge, distance and field strength, any one of these characteristics can be calculated when the other two are known. In the procedure, distance remains constant and charge of a probe is manipulated, causing a change in the strength of the electric field. By assuming that the objects involved in an interaction have a constant charge, we assert that as the distance between two objects decreases, the strength of the electric field between them increases, and *vice versa*. Therefore, by calculating the minimum stimulus charge and the minimum difference between two charges (i.e. resolution) that can be detected, we can make inferences about the range and sensitivity of electroreception in *B. terrestris*.

Understanding the range of electroreception could indicate which stage, if any, of foraging the sense is used in; if bees are able to sense electric fields of  $30\text{Vm}^{-1}$  and less (roughly equivalent to the field 1 metre away from a 30cm tall flower in a fair weather field), this could indicate that electrosensing is involved in the initial location of flowers. However, if higher field strengths are needed, it is likely that if electroreception does inform foraging behaviours, it is likely only to be used at close range, such as when bees are inspecting flowers prior to landing. Additionally, it is possible that certain aspects of the electrical signature of a flower can help elicit landing and post-landing foraging behaviours including proboscis extension and pollen gathering. This could be enabled by the increased charge densities seen in the centre of many flowers (see fig. 4.1) which could function as nectar or pollen guides. Linking this to the ability of bees to sense the geometry of electric fields (Clarke et al., 2013), further experimentation could be designed to determine how close to a stimulus a bee must be before it is able to discriminate different e-field geometries, providing further insight into the potential ways they use electrical information to inform foraging choices.

In the initial behavioural experiments of Clarke *et al.* (2013) examining discrimination of electrical stimuli by *B. terrestris*, bees were found to be able to identify rewarding artificial flowers with a potential of 30V, but were unable to make this discrimination when the charge of the flowers was set to 10V. This indicates that the field formed on approach to the 10V flowers was below the detection threshold of the bee. This is intriguing in the context of electrical information as a floral cue; as the electric potential of a flower is related to how far it extends above the ground, this may indicate that electrical information can only be used as a foraging cue with flowers taller than 10cm. There is some evidence that in the foxglove, *Penstemon digitalis*, there is significant selection pressure for individual plants to be taller (Parachnowitsch et al., 2012). Taller plants may also gain an advantage in initial detection by pollinators passing by and in access to sunlight for photosynthesis, though an increased height puts non-woody plants at a higher risk of wind damage; it would be interesting to compare the relative effect of these different selection pressures and the effects they have on plant height. It would also be worth exploring whether height contributes a significant selection pressure for other bumblebee-pollinated plants, such as tomatoes.

The experimental procedure could also provide insight into the role of electroreception in bumblebee social behaviour. In order to examine whether electroreception is used in intra- or interspecific communication two things must be considered: along with the sensory capabilities of *B. terrestris* and the resolution of its electric sense, the cues produced by con- and heterospecifics are of importance. If the sensory threshold for detection of electric fields is quite high, certain behaviours may not induce enough electric potential to be detected by a bee. However, as e-field strength is inversely proportional to the distance from an object, the closer a bee is to the source of electrical information, the higher the chance of the information being received. This indicates that electrical communication may be possible within the bumblebee nest, as in this environment bees are very close together. Further information on the

mechanism of charging in bees would illuminate further whether within-nest electrical communication is likely or even possible.

Similarly, when contemplating predator avoidance behaviour, the electrical footprint of predators should be considered. The electric potential of a predator will affect the distance from which it can be perceived by the bee, and therefore whether or not the bee is able to respond; if, for example, an avian predator has a high charge, it is more likely that the bee will be able to sense its approach with enough time to take evasive action. Additionally, bees may be able to gain information from the dynamics of an electric field over time: if a charged object is approaching the bee, the field strength will gradually increase, perhaps providing a warning against incoming threats.

#### **4.3.2 – Direction**

Directionality was chosen as an area for further investigation due to the potential implications directionality could have for our understanding of the functions of electroreception in *B. terrestris*. The procedure would aim to identify two characteristics of directionality in electrosensing: the ability of bees to determine what direction an electrical stimulus is coming from, relative to body orientation, and the ability of bees to detect electrical stimuli that are not directly in front of them, though not necessarily to be able to pinpoint the location of the stimulus.

The former would convey significant advantages in certain scenarios, particularly those involving interactions with other animals. For example, the ability to locate the source of an electrical pattern corresponding to a conspecific may help bees in searching for mates. Furthermore, this ability could have important implications for predator-prey interactions. A directional electric sense would not only enable bees to sense predators approaching, it would also facilitate appropriate reactive behaviour, increasing the chance of success in evasive manoeuvres. Vision is known to be important in some prey avoidance strategies of bumblebees (Ings et al., 2012), but perhaps electroreception could act as a backup for vision in some contexts and as the primary sensory modality in others.

It seems unlikely that the ability to discriminate the direction of the source of electrical information would be particularly useful in bumblebee foraging behaviour. Vision is known to play an important role in locating a flower to approach, with bees using the contrast between the corolla colour and the background to pinpoint inflorescences from above (Chittka et al., 2009; Lunau, 1992; Spaethe et al., 2001). It is possible that a directional component of electrosensing would allow bees to sense flowers out of their field of view when flying overhead, though if this were the case one might expect a reflection of this in the flight behaviour of the bee, with more turning and changing of direction. Additionally, as mentioned above, the ability of bees to sense an electrical stimulus is likely to increase the closer the bee is to a charged object, so when approaching a flower from a distance the electrical footprint of the flower may be below the detection threshold of the bee.

As well as detecting the direction of the source of electrical information, all of these examples rely on the ability of a bee to sense an electrical stimulus whilst oriented away from it. Even without the ability to pinpoint the location of the source of electrical information, this ability could increase the capacity of communication between bumblebees. For example, if electroreception is utilised during in-nest communication with conspecifics, it would be advantageous for electrical signals to be perceived by bees facing in all directions so as to be able to broadcast signals to as many individuals as possible, not just those which are oriented in the optimum direction. If electrical information can only be perceived by a bee facing the source, this would enable recipient-specific more ‘private’ signals to be shared; however, the social interactions of bees are usually not focussed on a specific individual, but aimed at as many individuals as possible (for example, in forager recruitment). Therefore, we would expect an omni-directional electric sense to be more adaptive in the context of intraspecific communication.

As discussed in chapter 3, the current procedure is not best placed to measure bees’ perception of slight differences in the direction of an electrical cue due to its bimodal design. The procedure could, however, shed light on whether the electric sense of bees is omni-directional or directed, and it could be adapted to focus further on directionality if a conditioned response to the change in direction of a stimulus could be learnt.

#### **4.4 – Aerial electroreception in other arthropods**

Sensory hairs are widespread throughout Arthropoda with many species having been shown to use mechanosensory hairs for detection of airborne vibrations and fluid flow-sensing (Casas & Dangles, 2010; Santer & Hebets, 2008; Steinmann et al., 2006). A recent study of the trichobothria of spiders (*Linyphiidae: Erigone*) revealed that these hairs respond with movement to electric fields and are therefore likely to cause discharges in the nerves of mechanoreceptors at the base of the hairs (Morley & Robert, 2018). Spiders do show behavioural responses to the presence of a vertical electric field, demonstrating they do have the ability to perceive electrical stimuli.

Although they function in a very similar way, trichobothria and the filiform hairs of insects are not homologous (Santer & Hebets, 2008). This indicates the electrosensitive ability of arachnids and insects is likely to be convergently evolved. As both trichobothria and insect filiform hairs act as bimodal sensors, being receptive to multiple sensory modalities (Koh & Robert, 2020; Morley & Robert, 2018) it is possible that the evolution of electric field detection by one or either of these sensory organs was driven by exaptation. The hairs could have evolved to maximise fluid-flow detection and incidentally become excellent electric field sensors, or *vice versa*. However, the variation in structural characteristics such as length and radius in filiform hairs of *B. terrestris* suggests that in this species at least, the evolution of the sensory hairs has been in response to selection pressures to maximise both electrical and vibration or fluid-flow sensing functions (Koh & Robert, 2020).

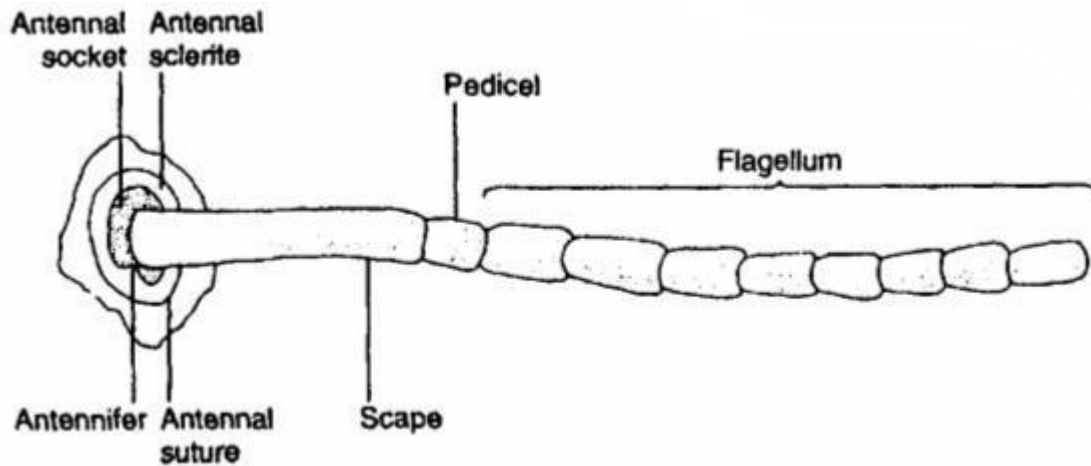

Figure 4.4 – General structure of an insect antenna showing the three main segments: the scape, pedicel and flagellum. The Johnston's Organ is within the pedicel. Adapted from Antenna [Electronic image]. (2015) Why And How Science. [www.whyhowscience.wordpress.com/2015/11/15/antenna/](http://www.whyhowscience.wordpress.com/2015/11/15/antenna/)

Not all insects which have demonstrated electrosensitivity have been shown to use filiform hairs for this purpose. Both the American cockroach (*Periplaneta americana*) and the honeybee (*Apis mellifera*) seem to use antennae to detect electric fields (Greggers et al., 2013; Newland et al., 2008). However, the mechanoreceptors involved seem to be in different locations in each species. In *A. mellifera*, movement around the flagellum-scape joint of the antenna (the Johnston's organ, JO, located in the pedicel; see fig. 4.4) whereas experiments have revealed the electric sense of *P. americana* relies upon movement at the scape-head joint. This is an important difference, again suggesting there may be independent origins in the mechanisms of electrosensing in these two species. However, filiform hairs have not been conclusively discounted as an electroreceptor in either of these species, so it is important to investigate whether the hairs of cockroaches and honeybees do act as electroreceptors before any assumptions about evolutionary origin can be made.

Due to the prevalence of both antennae and sensory hair structures in arthropods it is likely, if not inevitable, that other species are in possession of an electric sense. There seem to be two sensible starting points for exploring the phylogenetic spread of electroreception further: firstly, the focus could be on species which are closely related to those already known to be electroreceptive. For example, other *Bombus* species could be compared to *B. terrestris* to determine whether the sense is present throughout the genus, then the search could be broadened to other species of bee; investigations could perhaps focus on which species use filiform hairs as electroreceptors and which use antennae, in order to shed light on the differences in the electroreceptive mechanism between *A. mellifera* and *B. terrestris*.

The second starting point for exploring the spread of electroreception in arthropods is behaviour; species known to make use of vibrational or air-flow stimuli to inform specific behaviours may also be able to sense electrical stimuli. For example, the caterpillars of *Mamestra brassicae* are known to be able to sense the approach of the predatory wasp *Dolichovespula media* using airborne vibrations (Tautz & Markl, 1978).



As flying insects usually possess a positive charge – as is likely to be the case for *D. Vesputula* – the ability to sense the approach of a predator through electrical stimulation alone would provide *M. brassicae* with an alternative mechanism which may be able to function as a back-up in the case of environmental noise interference.

Electrical information is ubiquitous in the environment, so the list of potential functions of the sense in electroreceptive organisms is boundless. Species-specific uses of electrosensing will depend upon the individual biology of that species and, crucially, the environment it inhabits, though the evidence suggests the ability is likely to be widespread among terrestrial arthropods.

#### **4.5 – Areas for further research**

Further work is needed to explore the evolution and functionality of electroreception in *Bombus terrestris* and other terrestrial arthropods. The methodologies outlined in Chapter 3 would provide valuable insight into the spatial characteristics of electroreception in the buff-tailed bumblebee. Further priorities for research are outlined below.

The next steps for examining the electroreceptive abilities of *B. terrestris* begin with clarifying the sensory mechanism. So far, only filiform hairs on the dorsal side of the head of the bee have been tested for mechanical and electrophysiological responses to electrical stimuli (Sutton et al., 2016). However, bumblebees are covered in hairs of varying structures, and so it is likely that hairs on different areas of the body are also receptive to electrical stimulation. Understanding the distribution of electroreceptors across the body surface of the bee may provide an idea of the ecological functions and evolution of electroreception in this species and would provide further insight into the function of hairs as multimodal sensors.

Another priority for further research is clarifying whether filiform hairs play any role in electroreception in *Apis mellifera* through electrophysiological studies. This information may provide an indication of whether electroreception has evolved separately in the two species, or whether it is a conserved ability with one or other of the mechanisms (hair/antenna) having been lost in these species. As aforementioned, it may be helpful to study the response of other bee species to electroreception, and the sensory mechanism they use, in order to begin to map electrosensitivity onto a phylogeny. Again, this may give an indication as to whether electrosensing is conserved or whether it is an adaptive trait of certain arthropod species.

Finally, in order to clarify the function of electroreception in *B. terrestris*, it would be interesting to look in more detail at the role of floral electric fields in insect foraging behaviour. Several questions need addressing: do bees have an innate preference for certain electric field geometries? Have plants evolved to optimise their electric field geometry in order to appeal to a pre-existing sensory bias in bees? And,

perhaps most importantly of all, what information can bees gain from interacting with floral electric fields?

This area of research is overflowing with potential, with so many questions to answer and so many species to work with, and it will be exciting to watch how future research in the field unfolds.

#### **4.6 – Conclusion**

While the ability of *Bombus terrestris* to sense electric fields is now well recognised, many aspects of this sensory modality remain unclear. To date, the majority of the studies have focussed on the mechanism of the sense including the structure and responses of the electrical sense organs and the electrical ecology of the environment. Further research is now needed to elucidate the potential adaptive functions electrosensing performs in bees and the ways in which this sense has shaped the ecology and behaviour of *B. terrestris*, and *vice versa*.

The aims of the methodology presented in Chapter 3 are to expand on what is currently known about the physics and physiology of electrosensing in *B. terrestris*, and provide evidence for the spatial constraints of the sense in order to give an indication of the situations and functions in which it may be utilised.

Preliminary results suggest that the experimental design is appropriate for exploring responses of bees to different electrical stimuli, though adaptations may need to be made in order to be able to determine the sensitivity of bees to small changes in stimulus strength and direction.

Having reviewed the literature on the sensory modalities of the buff-tailed bumblebee, it is apparent that there are many potential ways electrical information could be integrated into the sensory landscape of the bee and influence its behavioural ecology. Further work is needed to explore which of the potential functions of electroreception correspond best with the sensory ability of the bees and the selection pressures under which the sense has evolved.

# References

- Abak, K., Dasgan, H. Y., Ikiz, Ö., Uygun, N., Kaftanoglu, O., Yeninar, H., & Sayalan, M. (1997). Pollen Production and Quality of Pepper Grown in Unheated Greenhouses During Winter and the Effects of Bumblebees (*Bombus terrestris*) Pollination on Fruit Yield and Quality. *Proceedings of the International Symposium on Pollination*, 437, 303–307.
- Abou-Shaara, H. F. (2018). An Inexpensive Method to Assess Associative Learning in Honey Bees Using the Proboscis Extension Reflex Test. *Bee World*, 95(1), 6–8.  
<https://doi.org/10.1080/0005772x.2017.1374767>
- Agin, V., Chichery, R., Dickel, L., & Chichery, M. P. (2006). The “prawn-in-the-tube” procedure in the cuttlefish: Habituation or passive avoidance learning? *Learning and Memory*, 13(1), 97–101.  
<https://doi.org/10.1101/lm.90106>
- Armbruster, W. S. (2001). Evolution of floral form: electrostatic forces, pollination, and adaptive compromise. *New Phytologist*, 152(2), 181–183. <https://doi.org/10.1046/j.0028-646X.2001.00268.x>
- Ayasse, M., & Jarau, S. (2014). Chemical Ecology of Bumble Bees. *Annual Review of Entomology*, 59(1), 299–319. <https://doi.org/10.1146/annurev-ento-011613-161949>
- Balamurali, G. S., Somanathan, H., & Hempel de Ibarra, N. (2015). Motion cues improve the performance of harnessed bees in a colour learning task. *Journal of Comparative Physiology A*, 201(5), 505–511. <https://doi.org/10.1007/s00359-015-0994-7>
- Banaszak-Cibicka, W., & Żmihorski, M. (2012). Wild bees along an urban gradient: winners and losers. *Journal of Insect Conservation*, 16(3), 331–343. <https://doi.org/10.1007/s10841-011-9419-2>
- Bennett, A. J., & Harrison, R. G. (2007). Atmospheric electricity in different weather conditions. *Weather*, 62(10), 277–283. <https://doi.org/10.1002/wea.97>
- Bicker, G., & Hähnlein, I. (1994). Long-term habituation of an appetitive reflex in the honeybee. *NeuroReport*, 6(1), 54–56. <https://doi.org/10.1097/00001756-199412300-00015>
- Bitterman, M. E., Menzel, R., Fietz, A., & Schäfer, S. (1983). Classical Conditioning of Proboscis Extension in Honeybees (*Apis mellifera*). *Journal of Comparative Psychology*, 97(2), 107–119.  
<https://doi.org/10.1037/0735-7036.97.2.107>
- Bowker, G. E., & Crenshaw, H. C. (2007). Electrostatic forces in wind-pollination—Part 1: Measurement of the electrostatic charge on pollen. *Atmospheric Environment*, 41(8), 1587–1595.  
<https://doi.org/10.1016/j.atmosenv.2006.10.047>

- Brody, L. R., Zelazo, P. R., & Chaika, H. (1984). Habituation-Dishabituation to speech in the neonate. *Developmental Psychology*, 20(1), 114–119. <https://doi.org/10.1037/0012-1649.20.1.114>
- Buchmann, S. L. (1985). Bees Use Vibration to Aid Pollen Collection from Non-Poricidal Flowers. *Journal of the Kansas Entomological Society*, 58(3), 517–525. <http://www.jstor.com/stable/25084671>
- Bullock, T. H. (1959). Initiation of Nerve Impulses in Receptor and Central Neurons. *Reviews of Modern Physics*, 31(2), 504–514. <https://doi.org/10.1103/RevModPhys.31.504>
- Byrne, J. H., & Hawkins, R. D. (2015). Nonassociative Learning in Invertebrates. *Cold Spring Harbor Perspectives in Biology*, 7(5), 1–16. <https://doi.org/10.1101/cshperspect.a021675>
- Carlson, Bruce A., & Sisneros, J. A. (2019). A Brief History of Electrogenesis and Electroreception in Fishes. In B. A. Carlson, J. A. Sisneros, A. Popper, & R. Fay (Eds.), *Electroreception: Fundamental Insights from Comparative Approaches*. (pp. 1–23). Springer, Cham. [https://doi.org/10.1007/978-3-030-29105-1\\_1](https://doi.org/10.1007/978-3-030-29105-1_1)
- Casas, J., & Dangles, O. (2010). Physical Ecology of Fluid Flow Sensing in Arthropods. *Annual Review of Entomology*, 55(1), 505–520. <https://doi.org/10.1146/annurev-ento-112408-085342>
- Ceuppens, B., Ameye, M., Van Langenhove, H., Roldan-Ruiz, I., & Smagghe, G. (2015). Characterization of volatiles in strawberry varieties ‘Elsanta’ and ‘Sonata’ and their effect on bumblebee flower visiting. *Arthropod-Plant Interactions*, 9(3), 281–287. <https://doi.org/10.1007/s11829-015-9375-y>
- Chakravarthi, A., Baird, E., Dacke, M., & Kelber, A. (2016). Spatial Vision in *Bombus terrestris*. *Frontiers in Behavioral Neuroscience*, 10(FEB), 1–8. <https://doi.org/10.3389/fnbeh.2016.00017>
- Chittka, L. (1996). Does Bee Color Vision Predate the Evolution of Flower Color? *Naturwissenschaften*, 83(3), 136–138. <https://doi.org/10.1007/s001140050263>
- Chittka, Lars. (2001). Camouflage of Predatory Crab Spiders on Flowers and the Colour Perception of Bees (Aranida: Thomisidae / Hymenoptera: Apidae). *Journal of General and Applied Entomology*, 25(3), 181–187.
- Chittka, Lars, Spaethe, J., Schmidt, A., & Hickelsberger, A. (2009). Adaptation, constraint, and chance in the evolution of flower color and pollinator color vision. In L. Chittka & J. D. Thomson (Eds.), *Cognitive Ecology of Pollination* (pp. 106–126). Cambridge University Press. <https://doi.org/10.1017/cbo9780511542268.007>
- Clarke, D., Morley, E., & Robert, D. (2017). The bee, the flower, and the electric field: electric ecology and aerial electroreception. *Journal of Comparative Physiology A*, 203(9), 737–748. <https://doi.org/10.1007/s00359-017-1176-6>

- Clarke, D., Whitney, H., Sutton, G., & Robert, D. (2013). Detection and Learning of Floral Electric Fields by Bumblebees. *Science*, *340*(6128), 66–69. <https://doi.org/10.1126/science.1230883>
- Collin, S. P. (2019). Electroreception in Vertebrates and Invertebrates. In *Encyclopedia of Animal Behavior* (Second Edi, Vol. 4, Issue May 2018). Elsevier. <https://doi.org/10.1016/B978-0-12-809633-8.01293-0>
- Corbet, S. A., Beament, J., & Eisikowitch, D. (1982). Are electrostatic forces involved in pollen transfer? *Plant, Cell & Environment*, *5*(2), 125–129. <https://doi.org/10.1111/1365-3040.ep11571488>
- Corfas, G., & Dudai, Y. (1989). Habituation and dishabituation of a cleaning reflex in normal and mutant *Drosophila*. *Journal of Neuroscience*, *9*(1), 56–62. <https://doi.org/10.1523/jneurosci.09-01-00056.1989>
- Crampton, W. G. R. (2019). Electroreception, electrogenesis and electric signal evolution. *Journal of Fish Biology*, *95*(1), 92–134. <https://doi.org/10.1111/jfb.13922>
- Czech-Damal, N. U., Dehnhardt, G., Manger, P., & Hanke, W. (2013). Passive electroreception in aquatic mammals. *Journal of Comparative Physiology A: Neuroethology, Sensory, Neural, and Behavioral Physiology*, *199*(6), 555–563. <https://doi.org/10.1007/s00359-012-0780-8>
- Dacke, M., Baird, E., Byrne, M., Scholtz, C. H., & Warrant, E. J. (2013). Dung Beetles Use the Milky Way for Orientation. *Current Biology*, *23*(4), 298–300. <https://doi.org/10.1016/j.cub.2012.12.034>
- Dacke, M., Bell, A. T. A., Foster, J. J., Baird, E. J., Strube-Bloss, M. F., Byrne, M. J., & el Jundi, B. (2019). Multimodal cue integration in the dung beetle compass. *Proceedings of the National Academy of Sciences of the United States of America*, *116*(28), 14248–14253. <https://doi.org/10.1073/pnas.1904308116>
- Dai, Y., & Law, S. E. (1995). Modeling the transient electric field produced by a charged pollen cloud entering a flower. *Conference Record - LAS Annual Meeting (IEEE Industry Applications Society)*, *2*, 1395–1402. <https://doi.org/10.1109/ias.1995.530465>
- De Luca, P. A., & Vallejo-Marín, M. (2013). What's the 'buzz' about? The ecology and evolutionary significance of buzz-pollination. *Current Opinion in Plant Biology*, *16*(4), 429–435. <https://doi.org/10.1016/j.pbi.2013.05.002>
- de Ruijter, A. (1997). Commercial Bumblebee Rearing and its Implications. *Proceedings of the International Symposium on Pollination*, *437*, 261–269.
- Dobson, H. E. M., Danielson, E. M., & Van Wesep, I. D. (1999). Pollen odor chemicals as modulators of bumble bee foraging on *Rosa rugosa* Thunb. (Rosaceae). *Plant Species Biology*, *14*(2), 153–166. <https://doi.org/10.1046/j.1442-1984.1999.00020.x>

- Dyer, A. G., & Chittka, L. (2004). Biological significance of distinguishing between similar colours in spectrally variable illumination: bumblebees (*Bombus terrestris*) as a case study. *Journal of Comparative Physiology A: Sensory, Neural, and Behavioral Physiology*, 190(2), 105–114.  
<https://doi.org/10.1007/s00359-003-0475-2>
- Dyer, Adrian G., Whitney, H. M., Arnold, S. E. J., Glover, B. J., & Chittka, L. (2007). Mutations perturbing petal cell shape and anthocyanin synthesis influence bumblebee perception of *Antirrhinum majus* flower colour. *Arthropod-Plant Interactions*, 1(1), 45–55.  
<https://doi.org/10.1007/s11829-007-9002-7>
- Edwards, D. K. (1960). Effects of Artificially Produced Atmospheric Electrical Fields Upon the Activity of Some Adult Diptera. *Canadian Journal of Zoology*, 38(5), 899–912. <https://doi.org/10.1139/z60-096>
- Essenberg, C. J. (2021). Intraspecific relationships between floral signals and rewards with implications for plant fitness. *AoB PLANTS*, 13(2), 1–17. <https://doi.org/10.1093/aobpla/plab006>
- Faraday, M. (1843). XXXII. On static electrical inductive action. *The London, Edinburgh, and Dublin Philosophical Magazine and Journal of Science*, 22(144), 200–204.  
<https://doi.org/10.1080/14786444308636351>
- Farrow, L. F., Barati, A., & McDonald, P. G. (2021). Cooperative bird discriminates between individuals based purely on their aerial alarm calls. *Behavioral Ecology*, 31(2), 440–447.  
<https://doi.org/10.1093/BEHECO/ARZ182>
- Foster, J. J., Sharkey, C. R., Gaworska, A. V. A., Roberts, N. W., Whitney, H. M., & Partridge, J. C. (2014). Bumblebees Learn Polarization Patterns. *Current Biology*, 24(12), 1415–1420.  
<https://doi.org/10.1016/j.cub.2014.05.007>
- Frisch, K. v. (1948). Die Tänze der Bienen. *Österreichische Zoologische Zeitschrift*, 1, 1–48.  
[https://www.zobodat.at/pdf/OEZ\\_01\\_0001-0048.pdf](https://www.zobodat.at/pdf/OEZ_01_0001-0048.pdf)
- Frittsch, B., & Wake, M. H. (1986). The Distribution of Ampullary Organs in Gymnophiona. *Journal of Herpetology*, 20(1), 90–93. <http://www.jstor.com/stable/1564133>
- Gómez, J. M., Perfectti, F., & Klingenberg, C. P. (2014). The role of pollinator diversity in the evolution of corolla-shape integration in a pollination-generalist plant clade. *Philosophical Transactions of the Royal Society B: Biological Sciences*, 369(1649). <https://doi.org/10.1098/rstb.2013.0257>
- Gould, E., McShea, W., & Grand, T. (1993). Function of the Star in the Star-Nosed Mole, *Condylura cristata*. *Journal of Mammalogy*, 74(1), 108–116.
- Goulson, D. (2010). *Bumblebees: Behaviour, Ecology, and Conservation* (Second Edn). Oxford University Press.

- Goulson, D., & Stout, J. C. (2001). Homing ability of the bumblebee *Bombus terrestris* (Hymenoptera: Apidae). *Apidologie*, *32*(1), 105–111. <https://doi.org/10.1051/apido:2001115>
- Goulson, Dave. (2019). The insect apocalypse, and why it matters. *Current Biology*, *29*(19), R967–R971. <https://doi.org/10.1016/j.cub.2019.06.069>
- Goulson, Dave, & Darvill, B. (2004). Niche overlap and diet breadth in bumblebees; are rare species more specialized in their choice of flowers? *Apidologie*, *35*(1), 55–63. <https://doi.org/10.1051/apido:2003062>
- Goulson, Dave, Lye, G. C., & Darvill, B. (2008). Diet breadth, coexistence and rarity in bumblebees. *Biodiversity and Conservation*, *17*(13), 3269–3288. <https://doi.org/10.1007/s10531-008-9428-y>
- Greggers, U., Koch, G., Schmidt, V., Dürr, A., Floriou-Servou, A., Piepenbrock, D., Göpfert, M. C., & Menzel, R. (2013). Reception and learning of electric fields in bees. *Proceedings of the Royal Society B: Biological Sciences*, *280*(1759), 1–8. <https://doi.org/10.1098/rspb.2013.0528>
- Gregory, J. E. (Department of P. U., Iggo, A., McIntyre, A. K., & Proske, U. (1989). Responses of Electroreceptors in the Snout of the Echidna. *Journal of Physiology*, *414*, 521–538.
- Hallmann, C. A., Sorg, M., Jongejans, E., Siepel, H., Hofland, N., Schwan, H., Stenmans, W., Müller, A., Sumser, H., Hörren, T., Goulson, D., & De Kroon, H. (2017). More than 75 percent decline over 27 years in total flying insect biomass in protected areas. *PLoS ONE*, *12*(10). <https://doi.org/10.1371/journal.pone.0185809>
- Harrap, M. J. M., Hempel de Ibarra, N., Whitney, H. M., & Rands, S. A. (2020). Floral temperature patterns can function as floral guides. *Arthropod-Plant Interactions*, *14*(2), 193–206. <https://doi.org/10.1007/s11829-020-09742-z>
- Harrap, M. J. M., Lawson, D. A., Whitney, H. M., & Rands, S. A. (2019). Cross-modal transfer in visual and nonvisual cues in bumblebees. *Journal of Comparative Physiology A: Neuroethology, Sensory, Neural, and Behavioral Physiology*, *205*(3), 427–437. <https://doi.org/10.1007/s00359-019-01320-w>
- Harrap, M. J. M., Rands, S. A., de Ibarra, N. H., & Whitney, H. M. (2017). The diversity of floral temperature patterns, and their use by pollinators. *ELife*, *6*, 1–18. <https://doi.org/10.7554/eLife.31262>
- Haupt, S. S., & Klemt, W. (2005). Habituation and dishabituation of exploratory and appetitive responses in the honey bee (*Apis mellifera* L.). *Behavioural Brain Research*, *165*(1), 12–17. <https://doi.org/10.1016/j.bbr.2005.06.030>
- Hill, P. S. M. (2008). *Vibrational Communication in Animals*. Harvard University Press.

- Humphrey, J. A. C., Barth, F. G., & Voss, K. (2001). The Motion-Sensing Hairs of Arthropods: Using Physics to Understand Sensory Ecology and Adaptive Evolution. In F. G. Barth & A. Schmid (Eds.), *Ecology of Sensing* (pp. 105–125). Springer, Berlin, Heidelberg. [https://doi.org/10.1007/978-3-662-22644-5\\_6](https://doi.org/10.1007/978-3-662-22644-5_6)
- Hunt, E. P., Jackson, C. W., & Newland, P. L. (2005). “Electrorepellancy” behaviour of *Periplaneta americana* exposed to friction charged dielectric surfaces. *Journal of Electrostatics*, *63*(6–10), 853–859. <https://doi.org/10.1016/j.elstat.2005.03.081>
- Hunt, J. H., & Richard, F. J. (2013). Intracolony vibroacoustic communication in social insects. *Insectes Sociaux*, *60*(4), 403–417. <https://doi.org/10.1007/s00040-013-0311-9>
- Ings, T. C., Wang, M. Y., & Chittka, L. (2012). Colour-independent shape recognition of cryptic predators by bumblebees. *Behavioral Ecology and Sociobiology*, *66*(3), 487–496. <https://doi.org/10.1007/s00265-011-1295-y>
- Jablonski, P. G., Cho, H. J., Song, S. R., Kang, C. K., & Lee, S. (2013). Warning signals confer advantage to prey in competition with predators: Bumblebees steal nests from insectivorous birds. *Behavioral Ecology and Sociobiology*, *67*(8), 1259–1267. <https://doi.org/10.1007/s00265-013-1553-2>
- Jackson, C. W., Hunt, E., Sharkh, S., & Newland, P. L. (2011). Static electric fields modify the locomotory behaviour of cockroaches. *Journal of Experimental Biology*, *214*(12), 2020–2026. <https://doi.org/10.1242/jeb.053470>
- Jarau, S., Žáček, P., Šobotník, J., Vrkoš, V., Hadravová, R., Coppée, A., Vašíčková, S., Jiroš, P., & Valterová, I. (2012). Leg tendon glands in male bumblebees (*Bombus terrestris*): structure, secretion chemistry, and possible functions. *Naturwissenschaften*, *99*(12), 1039–1049. <https://doi.org/10.1007/s00114-012-0986-1>
- Jersáková, J., Jürgens, A., Šmilauer, P., & Johnson, S. D. (2012). The evolution of floral mimicry: Identifying traits that visually attract pollinators. *Functional Ecology*, *26*(6), 1381–1389. <https://doi.org/10.1111/j.1365-2435.2012.02059.x>
- Kadmon, R., & Shmida, A. (1992). Departure rules used by bees foraging for nectar: a field test. *Evolutionary Ecology*, *6*(2), 142–151. <https://doi.org/10.1007/BF02270708>
- Kaspi, R., & Shafir, S. (2013). Associative olfactory learning of the red dwarf honey bee *Apis florea*. *Apidologie*, *44*(1), 100–109. <https://doi.org/10.1007/s13592-012-0160-y>
- Katzenberger, T. D., Lunau, K., & Junker, R. R. (2013). Salience of multimodal flower cues manipulates initial responses and facilitates learning performance of bumblebees. *Behavioral Ecology and*



- Sociobiology*, 67(10), 1587–1599. <https://doi.org/10.1007/s00265-013-1570-1>
- Kevan, P. G., & Lane, M. A. (1985). Flower petal microtexture is a tactile cue for bees. *Proceedings of the National Academy of Sciences*, 82(14), 4750–4752. <https://doi.org/10.1073/pnas.82.14.4750>
- Kirchner, W. H. (1993). Acoustical communication in honeybees. *Apidologie*, 24(3), 297–307. <https://doi.org/10.1051/apido:19930309>
- Kirchner, W. H., & Röschard, J. (1999). Hissing in bumblebees: an interspecific defence signal. *Insectes Sociaux*, 46(3), 239–243. <https://doi.org/10.1007/s000400050140>
- Kisilevsky, B. S., & Muir, D. W. (1984). Neonatal Habituation and Dishabituation to Tactile Stimulation During Sleep. *Developmental Psychology*, 20(3), 367–373. <https://doi.org/10.1037/0012-1649.20.3.367>
- Kitaoka, T. K., & Nieh, J. C. (2009). Manuscript in preparation for Behavioral Ecology and Sociobiology Bumble bee pollen foraging regulation: role of pollen quality, storage levels, and odor. *Behavioral Ecology and Sociobiology*, 63(4), 501–510. <https://doi.org/10.1007/s00265-008-0684-3>
- Knight, M. E., Martin, A. P., Bishop, S., Osborne, J. L., Hale, R. J., Sanderson, R. A., & Goulson, D. (2005). An interspecific comparison of foraging range and nest density of four bumblebee (*Bombus*) species. *Molecular Ecology*, 14(6), 1811–1820. <https://doi.org/10.1111/j.1365-294X.2005.02540.x>
- Koh, K. L., Montgomery, C., Clarke, D., Morley, E. L., & Robert, D. (2019). Bumblebee hair motion in electric fields. *Journal of Physics: Conference Series*, 1322(1), 012001. <https://doi.org/10.1088/1742-6596/1322/1/012001>
- Koh, K., & Robert, D. (2020). Bumblebee hairs as electric and air motion sensors: theoretical analysis of an isolated hair. *Journal of The Royal Society Interface*, 17(168), 20200146. <https://doi.org/10.1098/rsif.2020.0146>
- Krishna, S., & Keasar, T. (2018). Morphological Complexity as a Floral Signal: From Perception by Insect Pollinators to Co-Evolutionary Implications. *International Journal of Molecular Sciences*, 19(6), 1681. <https://doi.org/10.3390/ijms19061681>
- Lawson, D. A., Chittka, L., Whitney, H. M., & Rands, S. A. (2018). Bumblebees distinguish floral scent patterns, and can transfer these to corresponding visual patterns. *Proceedings of the Royal Society B: Biological Sciences*, 285(1880), 20180661. <https://doi.org/10.1098/rspb.2018.0661>
- Lawson, D. A., Whitney, H. M., & Rands, S. A. (2017). Colour as a backup for scent in the presence of olfactory noise: testing the efficacy backup hypothesis using bumblebees (*Bombus terrestris*). *Royal Society Open Science*, 4(11), 1–13. <https://doi.org/10.1098/rsos.170996>

- Lehrer, M., Srinivasan, M. V., Zhang, S. W., & Horridge, G. A. (1988). Motion cues provide the bee's visual world with a third dimension. In *Nature* (Vol. 332, Issue 6162, pp. 356–357).  
<https://doi.org/10.1038/332356a0>
- Leonard, A. S., Dornhaus, A., & Papaj, D. R. (2011). Flowers help bees cope with uncertainty: signal detection and the function of floral complexity. *Journal of Experimental Biology*, *214*(1), 113–121.  
<https://doi.org/10.1242/jeb.047407>
- Leonard, A. S., & Papaj, D. R. (2011). “X” marks the spot: The possible benefits of nectar guides to bees and plants. *Functional Ecology*, *25*(6), 1293–1301. <https://doi.org/10.1111/j.1365-2435.2011.01885.x>
- Lissmann, H. W. (1951). Continuous Electrical Signals from the Tail of a Fish, *Gymnarchus niloticus* Cuv. *Nature*, *167*, 201–202.
- Lunau, K. (1992). Innate recognition of flowers by bumble bees: orientation of antennae to visual stamen signals. *Canadian Journal of Zoology*, *70*(11), 2139–2144. <https://doi.org/10.1139/z92-288>
- Luo, E. Y., Ogilvie, J. E., & Thomson, J. D. (2014). Stimulation of flower nectar replenishment by removal: A survey of eleven animal-pollinated plant species. *Journal of Pollination Ecology*, *12*(7), 52–62. [https://doi.org/10.26786/1920-7603\(2014\)2](https://doi.org/10.26786/1920-7603(2014)2)
- Lye, G. C., Osborne, J. L., Park, K. J., & Goulson, D. (2012). Using citizen science to monitor *Bombus* populations in the UK: nesting ecology and relative abundance in the urban environment. *Journal of Insect Conservation*, *16*(5), 697–707. <https://doi.org/10.1007/s10841-011-9450-3>
- Macuda, T., Gegear, R. J., Laverty, T. M., & Timney, B. (2001). Behavioural assessment of visual acuity in bumblebees (*Bombus impatiens*). *Journal of Experimental Biology*, *204*(3), 559–564.
- Mangiacotti, M., Martín, J., López, P., Reyes-Olivares, C. V., Rodríguez-Ruiz, G., Coladonato, A. J., Scali, S., Zuffi, M. A. L., & Sacchi, R. (2020). Proteins from femoral gland secretions of male rock lizards *Iberolacerta cyreni* allow self—but not individual—recognition of unfamiliar males. *Behavioral Ecology and Sociobiology*, *74*(6). <https://doi.org/10.1007/s00265-020-02847-8>
- Matsumoto, Y., Menzel, R., Sandoz, J. C., & Giurfa, M. (2012). Revisiting olfactory classical conditioning of the proboscis extension response in honey bees: A step toward standardized procedures. *Journal of Neuroscience Methods*, *211*(1), 159–167. <https://doi.org/10.1016/j.jneumeth.2012.08.018>
- Maw, M. G. (1961). Behaviour of an Insect on an Electrically Charged Surface. *The Canadian Entomologist*, *93*(5), 391–393. <https://doi.org/10.4039/Ent93391-5>
- Messina, A., Potrich, D., Schiona, I., Sovrano, V. A., Fraser, S. E., Brennan, C. H., & Vallortigara, G. (2020). Response to change in the number of visual stimuli in zebrafish: A behavioural and

- molecular study. *Scientific Reports*, 10(1), 1–11. <https://doi.org/10.1038/s41598-020-62608-5>
- Meyer-Rochow, V. B. (2019). Eyes and Vision of the Bumblebee: a Brief Review on how Bumblebees Detect and Perceive Flowers. *Journal of Apiculture*, 34(2), 107–115. <https://doi.org/10.17519/apiculture.2019.06.34.2.107>
- Molet, M., Chittka, L., & Raine, N. E. (2009). How floral odours are learned inside the bumblebee (*Bombus terrestris*) nest. *Naturwissenschaften*, 96(2), 213–219. <https://doi.org/10.1007/s00114-008-0465-x>
- Montgomery, C., Koh, K., & Robert, D. (2019). Measurement of electric charges on foraging bumblebees (*Bombus terrestris*). *Journal of Physics: Conference Series*, 1322(1), 012002. <https://doi.org/10.1088/1742-6596/1322/1/012002>
- Morley, E. L., & Robert, D. (2018). Electric Fields Elicit Ballooning in Spiders. *Current Biology*, 28(14), 2324–2330.e2. <https://doi.org/10.1016/j.cub.2018.05.057>
- Morse, D. H. (1983). Foraging patterns and time budgets of the crab spiders *Xysticus emertoni* (Keyserling) and *Misumena vatia* (Clerck) (Araneae : Thomisidae) on Flowers. *The Journal of Arachnology*, 11, 87–94.
- Morse, D. H. (1986). Foraging Behavior of Crab Spiders (*Misumena vatia*) Hunting on Inflorescences of Different Quality. *The American Midland Naturalist*, 116(2), 341–347. <http://www.jstor.com/stable/2425742>
- Newland, P. L., Hunt, E., Sharkh, S. M., Hama, N., Takahata, M., & Jackson, C. W. (2008). Static electric field detection and behavioural avoidance in cockroaches. *Journal of Experimental Biology*, 211(23), 3682–3690. <https://doi.org/10.1242/jeb.019901>
- Parachnowitsch, A. L., Raguso, R. A., & Kessler, A. (2012). Phenotypic selection to increase floral scent emission, but not flower size or colour in bee-pollinated *Penstemon digitalis*. *New Phytologist*, 195(3), 667–675. <https://doi.org/10.1111/j.1469-8137.2012.04188.x>
- Patullo, B. W., & Macmillan, D. L. (2007). Crayfish respond to electrical fields. *Current Biology*, 17(3), 83–84. <https://doi.org/10.1016/j.cub.2006.11.048>
- Patullo, B. W., & Macmillan, D. L. (2010). Making sense of electrical sense in crayfish. *Journal of Experimental Biology*, 213(4), 651–657. <https://doi.org/10.1242/jeb.039073>
- Pearce, R. F., Giuggioli, L., & Rands, S. A. (2017). Bumblebees can discriminate between scent-marks deposited by conspecifics. *Scientific Reports*, 7, 1–11. <https://doi.org/10.1038/srep43872>
- Peat, J., Tucker, J., & Goulson, D. (2005). Does intraspecific size variation in bumblebees allow colonies

- to efficiently exploit different flowers? *Ecological Entomology*, *30*(2), 176–181.  
<https://doi.org/10.1111/j.0307-6946.2005.00676.x>
- Pellmyr, O., & Thien, L. B. (1986). Insect Reproduction and Floral Fragrances: Keys To the Evolution of the Angiosperms? *Taxon*, *35*(1), 76–85. <https://doi.org/10.2307/1221036>
- Pettigrew, J. D. (1999). Electroreception in monotremes. *Journal of Experimental Biology*, *202*(10), 1447–1454.
- Plowright, C. M. S., Simonds, V. M., & Butler, M. A. (2006). How bumblebees first find flowers: Habituation of visual pattern preferences, spontaneous recovery, and dishabituation. *Learning and Motivation*, *37*(1), 66–78. <https://doi.org/10.1016/j.lmot.2005.03.002>
- Price, C. J., Banks, P. B., Brown, S., Latham, M. C., Latham, A. D. M., Pech, R. P., & Norbury, G. L. (2020). Invasive mammalian predators habituate to and generalize avian prey cues: a mechanism for conserving native prey. *Ecological Applications*, *30*(8), 1–11. <https://doi.org/10.1002/eap.2200>
- Prýs-Jones, O. E., & Corbet, S. A. (1987). *Bumblebees (Naturalists' Handbooks, Volume 6)*. Cambridge University Press.
- Rader, R., Bartomeus, I., Tylianakis, J. M., & Laliberté, E. (2014). The winners and losers of land use intensification: pollinator community disassembly is non-random and alters functional diversity. *Diversity and Distributions*, *20*(8), 908–917. <https://doi.org/10.1111/ddi.12221>
- Raguso, R. A. (2009). Floral scent in a whole-plant context : moving beyond pollinator attraction. *Functional Ecology*, *23*, 837–840. <https://doi.org/10.1111/j.1365-2435.2009.01643.x>
- Ramírez, S. R. (1991). Orchid bees. *Current Biology*, *19*(23), R1061–R1063.
- Ramirez, S. R., Eltz, T., Fujiwara, M. K., Gerlach, G., Goldman-Huertas, B., Tsutsui, N. D., & Pierce, N. E. (2011). Asynchronous Diversification in a Specialized Plant-Pollinator Mutualism. *Science*, *333*(6050), 1742–1746. <https://doi.org/10.1126/science.1209175>
- Rands, S. A., Glover, B. J., & Whitney, H. M. (2011). Floral epidermal structure and flower orientation: getting to grips with awkward flowers. *Arthropod-Plant Interactions*, *5*(4), 279–285.  
<https://doi.org/10.1007/s11829-011-9146-3>
- Root-Gutteridge, H., Ratcliffe, V. F., Korzeniowska, A. T., & Reby, D. (2019). Dogs perceive and spontaneously normalize formant-related speaker and vowel differences in human speech sounds. *Biology Letters*, *15*(12). <https://doi.org/10.1098/rsbl.2019.0555>
- Rowe, C., & Guilford, T. (1999). The evolution of multimodal warning displays. *Evolutionary Ecology*, *13*(7–

- 8), 655–671. <https://doi.org/10.1023/A:1011021630244>
- Rycroft, M. J., Israelsson, S., & Price, C. (2000). The global atmospheric electric circuit, solar activity and climate change. *Journal of Atmospheric and Solar-Terrestrial Physics*, *62*(17–18), 1563–1576. [https://doi.org/10.1016/S1364-6826\(00\)00112-7](https://doi.org/10.1016/S1364-6826(00)00112-7)
- Rycroft, Michael J., & Harrison, R. G. (2012). Electromagnetic Atmosphere-Plasma Coupling: The Global Atmospheric Electric Circuit. *Space Science Reviews*, *168*(1–4), 363–384. <https://doi.org/10.1007/s11214-011-9830-8>
- Saleh, N., Scott, A. G., Bryning, G. P., & Chittka, L. (2007). Distinguishing signals and cues: bumblebees use general footprints to generate adaptive behaviour at flowers and nest. *Arthropod-Plant Interactions*, *1*(2), 119–127. <https://doi.org/10.1007/s11829-007-9011-6>
- Santer, R. D., & Hebets, E. A. (2008). Agonistic signals received by an arthropod filiform hair allude to the prevalence of near-field sound communication. *Proceedings of the Royal Society B: Biological Sciences*, *275*(1633), 363–368. <https://doi.org/10.1098/rspb.2007.1466>
- Schiestl, F. P., & Dötterl, S. (2012). The Evolution of Floral Scent and Olfactory Preferences in Pollinators: Coevolution or Pre-existing Bias? *Evolution*, *66*(7), 2042–2055. <https://doi.org/10.1111/j.1558-5646.2012.01593.x>
- Schiestl, F. P., Huber, F. K., & Gomez, J. M. (2011). Phenotypic selection on floral scent: trade-off between attraction and deterrence? *Evolutionary Ecology*, *25*(2), 237–248. <https://doi.org/10.1007/s10682-010-9409-y>
- Schiestl, F. P., & Johnson, S. D. (2013). Pollinator-mediated evolution of floral signals. *Trends in Ecology and Evolution*, *28*(5), 307–315. <https://doi.org/10.1016/j.tree.2013.01.019>
- Schmitt, U., & Bertsch, A. (1990). Do foraging bumblebees scent-mark food sources and does it matter? *Oecologia*, *82*(1), 137–144. <https://doi.org/10.1007/BF00318545>
- Schulte, A. J., Mail, M., Hahn, L. A., & Barthlott, W. (2019). Ultraviolet patterns of flowers revealed in polymer replica - caused by surface architecture. *Beilstein Journal of Nanotechnology*, *10*(1), 459–466. <https://doi.org/10.3762/bjnano.10.45>
- Shimizu, A., Dohzono, I., Nakaji, M., Roff, D. A., Miller, D. G., Osato, S., Yajima, T., Niitsu, S., Utsugi, N., Sugawara, T., & Yoshimura, J. (2014). Fine-tuned bee-flower Coevolutionary state hidden within multiple pollination interactions. *Scientific Reports*, *4*(3988), 1–9. <https://doi.org/10.1038/srep03988>
- Siddall, E. C., & Marples, N. M. (2011). Hear no evil: The effect of auditory warning signals on avian innate avoidance, learned avoidance and memory. *Current Zoology*, *57*(2), 197–207.

<https://doi.org/10.1093/czoolo/57.2.197>





- Smith, S. D., & Kriebel, R. (2018). Convergent evolution of floral shape tied to pollinator shifts in Iochrominae (Solanaceae)\*. *Evolution*, 72(3), 688–697. <https://doi.org/10.1111/evo.13416>
- Spaethe, J., Tautz, J., & Chittka, L. (2001). Visual constraints in foraging bumblebees: Flower size and color affect search time and flight behavior. *Proceedings of the National Academy of Sciences of the United States of America*, 98(7), 3898–3903. <https://doi.org/10.1073/pnas.071053098>
- Steinmann, T., Casas, J., Krijnen, G., & Dangles, O. (2006). Air-flow sensitive hairs: boundary layers in oscillatory flows around arthropod appendages. *Journal of Experimental Biology*, 209(21), 4398–4408. <https://doi.org/10.1242/jeb.02506>
- Steullet, P., Edwards, D. H., & Derby, C. D. (2007). An Electric Sense in Crayfish? *Biological Bulletin*, 213(1), 16–20. <https://doi.org/10.2307/25066614>
- Strauss, S. Y., & Whittall, J. B. (2006). Non-pollinator agents of selection on floral traits. In *Ecology and evolution of flowers* (pp. 120–138). [http://www.researchgate.net/profile/Sharon\\_Strauss/publication/254469747\\_Non-pollinator\\_agents\\_of\\_selection\\_on\\_floral\\_traits/links/53d275b60cf220632f3c9c39.pdf%5Cnpapers2://publication/uuid/F1BC2A23-C948-4B44-A97C-C6D1A238C113](http://www.researchgate.net/profile/Sharon_Strauss/publication/254469747_Non-pollinator_agents_of_selection_on_floral_traits/links/53d275b60cf220632f3c9c39.pdf%5Cnpapers2://publication/uuid/F1BC2A23-C948-4B44-A97C-C6D1A238C113)
- Su, D. K.-N. (2009). Bumblebee vibration activated foraging [University of California, San Diego]. In *Peer reviewed | Thesis/dissertation*. <https://escholarship.org/uc/item/0xp4r2hb>
- Sutton, G. P., Clarke, D., Morley, E. L., & Robert, D. (2016). Mechanosensory hairs in bumblebees (*Bombus terrestris*) detect weak electric fields. *Proceedings of the National Academy of Sciences of the United States of America*, 113(26), 7261–7265. <https://doi.org/10.1073/pnas.1601624113>
- Tautz, J., & Markl, H. (1978). Caterpillars Detect Flying Wasps by Hairs Sensitive to Airborne Vibration. *Behavioral Ecology and Sociobiology*, 4(1), 101–110. <https://doi.org/10.1007/BF00302564>
- Taylor, G. J., Tichit, P., Schmidt, M. D., Bodey, A. J., Rau, C., & Baird, E. (2019). Bumblebee visual allometry results in locally improved resolution and globally improved sensitivity. *ELife*, 8, 1–32. <https://doi.org/10.7554/eLife.40613>
- Towne, W. F., & Kirchner, W. H. (1989). Hearing in Honey Bees: Detection of Air-Particle Oscillations. *Science*, 244(4905), 686–688. <https://doi.org/10.1126/science.244.4905.686>
- Towne, William F. (1995). Frequency Discrimination in the Hearing of Honey Bees (Hymenoptera: Apidae). *Journal of Insect Behavior*, 8(2), 281–286. <https://doi.org/10.1007/BF01988911>

- Vaknin, Y., Gan-Mor, S., Bechar, A., Ronen, B., & Eisikowitch, D. (2000). The role of electrostatic forces in pollination. *Plant Systematics and Evolution*, 222, 133–142.  
<https://doi.org/10.1103/PhysRevB.36.3542>
- van den Eijnde, J., de Ruijter, A., & van der Steen, J. (1991). Method for Rearing *Bombus terrestris* Continuously and the Production of Bumblebee Colonies for Pollination Purposes. In *Acta Horticulturae* (Vol. 288, pp. 154–158). <https://doi.org/10.17660/ActaHortic.1991.288.20>
- Varnon, C. A., Vallely, N., Beheler, C., & Coffin, C. (2021). The disturbance leg-lift response (DLR): An undescribed behavior in bumble bees. *PeerJ*, 9. <https://doi.org/10.7717/peerj.10997>
- von Arx, M. (2013). Floral humidity and other indicators of energy rewards in pollination biology. *Communicative and Integrative Biology*, 6(1), e22750. <https://doi.org/10.4161/cib.22750>
- von Arx, M., Goyret, J., Davidowitz, G., & Raguso, R. A. (2012). Floral humidity as a reliable sensory cue for profitability assessment by nectar-foraging hawkmoths. *Proceedings of the National Academy of Sciences of the United States of America*, 109(24), 9471–9476. <https://doi.org/10.1073/pnas.1121624109>
- Wilmsen, S., Gottlieb, R., Junker, R. R., & Lunau, K. (2017). Bumblebees require visual pollen stimuli to initiate and multimodal stimuli to complete a full behavioral sequence in close-range flower orientation. *Ecology and Evolution*, 7(5), 1384–1393. <https://doi.org/10.1002/ece3.2768>
- Zung, J. L., Forrest, J. R. K., Castellanos, M. C., & Thomson, J. D. (2015). Bee- to bird-pollination shifts in Penstemon: effects of floral-lip removal and corolla constriction on the preferences of free-foraging bumble bees. *Evolutionary Ecology*, 29(3), 341–354. <https://doi.org/10.1007/s10682-014-9716-9>

# Appendices

## Appendix 1: Harness materials

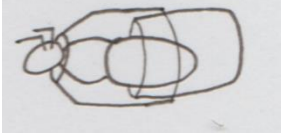
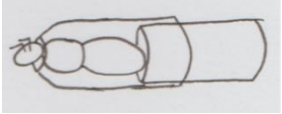
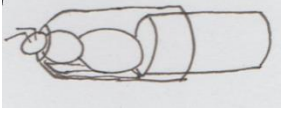
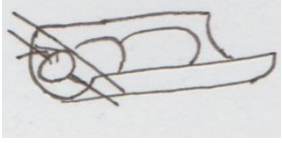
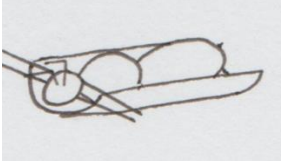
The table below contains details of the eight harness designs tested and the materials they were made of.

Design	Illustration	Materials
A		Moulded polymer clay base (FIMO); legs held in place with modelling wax (indicated on diagram by red crosses).
B		As A, but left overnight in the bumblebee nest beforehand.
C		Bulb from 1ml graduated pipette.
D		Bulb from 1ml graduated pipette, cotton stopper behind bee.
E		Bulb from 1ml graduated pipette, cotton stopper behind bee, cotton base beneath bee.
F		Hard plastic half-cylinder; head held in place by wire 'stocks'.
G		As F, but shallower half-cylinder.
H		Bee glued by thorax to wooden skewer.



