



Vardanega, P. J., & Bolton, M. D. (2016). Design of Geostructural Systems. *ASCE-ASME Journal of Risk and Uncertainty in Engineering Systems, Part A: Civil Engineering*, 2(1), [04015017].
<https://doi.org/10.1061/AJRUA6.0000849>

Peer reviewed version

Link to published version (if available):
[10.1061/AJRUA6.0000849](https://doi.org/10.1061/AJRUA6.0000849)

[Link to publication record in Explore Bristol Research](#)
PDF-document

Vardanega, P. and Bolton, M. (2015). "Design of Geostructural Systems." *ASCE-ASME J. Risk Uncertainty Eng. Syst., Part A: Civ. Eng.*, 10.1061/AJRUA6.0000849, 04015017. This material may be downloaded for personal use only. Any other use requires prior permission of the American Society of Civil Engineers.

University of Bristol - Explore Bristol Research

General rights

This document is made available in accordance with publisher policies. Please cite only the published version using the reference above. Full terms of use are available:
<http://www.bristol.ac.uk/red/research-policy/pure/user-guides/ebr-terms/>

This is the author version of a paper that was accepted for publication in the *ASCE-ASME Journal of Risk and Uncertainty in Engineering Systems, Part A: Civil Engineering* on 15 September 2015. This author version is an edited version of the final draft of the manuscript. Further alterations to the final draft may have been introduced during the publishing process, such as: formatting changes and resolution of other minor typographical errors.

For the final version of record please refer to the published version at:

<http://dx.doi.org/10.1061/AJRUA6.0000849>

PJV

28-10-2015

Design of Geostructural Systems

P. J. Vardanega, Ph.D., M.ASCE¹ and M. D. Bolton, Ph.D. C.Eng.²

Abstract: This paper begins with an extensive review of the literature covering the development of design rules for geostructural systems, beginning with traditional global safety factors and developing through partial factors for loads and resistances, and then considering the use of mobilization factors to limit soil strains. The paper then aims to distinguish two possible functions for geotechnical factors: to compensate for the uncertainty regarding soil strength, and to limit soil deformations that could compromise the associated structure before the soil strength can be fully mobilized, whatever it is. At present, design procedures generally conflate and confuse ultimate limit state (ULS) checks and serviceability limit state (SLS) deformation checks. Furthermore, most geotechnical engineers wrongly associate ULS with soil failure rather than with structural failure. The paper addresses this fundamental confusion by advocating mobilizable strength design (MSD), which is based on assumed soil-structure deformation mechanisms rather than soil failure mechanisms. It is argued that designs using MSD can guard against damaging structural deformations, either small deformations giving SLS or large structural deformations that must be regarded as ULS even though the associated soil strength may not yet be fully mobilized. This distinction effectively challenges much of the previous literature on limit state design principles for geotechnical applications, even where probabilistic approaches have been proposed. Nevertheless, the paper is informed by the concepts and techniques of decision making under uncertainty, and the paper concludes by considering whether MSD can also be placed in a reliability framework.

Author keywords: Geotechnical design; Safety; Serviceability; Factors of safety; Reliability;

Review

¹ Lecturer in Civil Engineering, Department of Civil Engineering, University of Bristol, Bristol, BS8 1TR, United Kingdom. Email: p.j.vardanega@bristol.ac.uk (corresponding author)

² Emeritus Professor of Soil Mechanics, Department of Engineering, University of Cambridge, Cambridge, CB2 1PZ, United Kingdom. Email: mdb8@cam.ac.uk

INTRODUCTION

Geostructural systems are inherently variable. There is variability in load combinations and other actions, variability of material properties in space (heterogeneity) and with time (process), variability in the behavioural mechanisms that need to be invoked to predict the system response, and variability with respect to the consequences for human safety or property damage of an error in predicting that response. Furthermore, the exceptional non-linearity of geostructural systems creates additional difficulties both for the definition of appropriate material parameters and for the selection of appropriate behaviour mechanisms.

The field of civil engineering as a whole is characterised by the great uncertainties of the one-off construction of expensive and extensive infrastructure schemes that depend on unreliable materials, weather and human behaviour for their success. Within civil engineering, geotechnical engineering is arguably the most susceptible to these factors and therefore the most difficult to deal with. Perhaps for this reason, the cultures of decision making in geotechnical and structural design have diverged, creating additional communication difficulties on the topic of risk and reliability.

Similar to other branches of civil engineering, geotechnical engineering tends to be focused on the prevention of any sort of *failure*. Leonards (1982) describes failure as the “unacceptable difference between expected and observed performance”. Expressing the task positively, geotechnical structures must be designed so as to satisfy their intended performance outcomes. Engineers try to achieve this by using various mechanical checks, along with rules of thumb that have proven useful in previously successful projects.

The aim of this paper is to review the evolution of methods for the evaluation of geostructural systems for the purposes of design, from simple safety factors through partial factors and the development of reliability assessments, to practical performance evaluations

that shift the focus to serviceability. The topic ultimately under discussion will be good decision making under uncertainty, accounting for the inherent variability and nonlinearity of the systems under discussion. One key issue that must be faced is the balance between the creation of design rules and their application in practice by well-educated professionals using their own judgment.

Failure

Geotechnical engineers are generally taught about past examples of failure early in their education (Morley 1996). The engineering student will often be exposed to discussion on prominent failures such as the Aberfan disaster in Wales (HMSO 1967) and the failure of the Teton Dam (U. S. Department of the Interior Teton Dam Failure Review Group 1977), each of which was so catastrophic as to wipe out much of the evidence of their actual causes, leading to continuing speculation concerning mechanisms of cracking, fluid transmission and soil liquefaction. The geotechnical failures by tilting of the Transcona Grain Elevator ultimate collapse (Peck and Bryant 1953) and The Leaning Tower of Pisa which represented a repairable serviceability failure (Terracina 1962) were more amenable to the verification of mechanisms by back-analysis. Designers must anticipate how their designs could fail (if built) so that catastrophic events can be prevented; this is why case studies are essential (Petroski 1994). Until recently, however, the focus of attention was placed on mechanisms of ultimate collapse, rather than unserviceability. Geotechnics is perhaps the only branch of engineering in which the performance in service of manufactured goods is rarely the keystone of the design process.

The potentially damaging effects of settlement and differential settlement have, however, been collated and discussed for over 60 years (Meyerhof 1953, Skempton and Macdonald 1956, Polshin and Tokar 1957, Burland and Wroth 1975, Meyerhof 1982, Boscardin and

Cording 1989 and Poulos et al. 2001). The various definitions that were found to be useful in categorising the causes of structural damage are (cf. Poulos et al. 2001):

- Overall settlement, w ;
- Tilt (local and overall), θ ;
- Angular distortion (or relative rotation), β ; and
- Relative deflection, $\Delta w/L$.

In this paper, the authors follow Burland et al. (2004) in preferring relative deflection as the most practical definition of differential settlement for the purposes of estimating damage in structures that are continuous over shallow foundations (e.g., storage tanks on rafts, framed structures with pad foundations, buildings with load-bearing walls on strip foundations, bridge decks continuous over three or more supports).

Boscardin and Cording (1989) also studied the link between building damage and the combination of horizontal strain and angular distortion induced by ground movements due to nearby excavations or tunneling. However, Burland et al. (2004) demonstrated from careful field records that integral foundations such as rafts offered immunity to elongation, reducing the additional consideration of horizontal ground strains to the estimation of subsidence damage in buildings on separate footings.

Table 1 summarises the various limits suggested by previous authorities; these limits are linked with terms that might be found in a risk analysis. In cases in which authorities have preferred to quote limiting values of angular distortion β , this has been halved in Table 1 to derive an approximate value for the equivalent relative deflection $\Delta w/L$, assuming a parabolic profile. Very severe cracking accompanied by relative deflections of the order of 1/300 is referred to in this paper as a hazard, on the grounds that segments of masonry will have become isolated by wide cracks, and made vulnerable to collapse out of plane under differential wind pressures. Moderate to severe cracking is referred to as a violation of

serviceability requirements, because the owner would surely regard the consequent lack of weatherproofing and the likely jamming of doors and distortion of windows as intolerable. Loss of the good appearance of the structure might, in comparison, be regarded simply as disappointing, as it could be rectified at a cost, presumably to be borne by the constructors and their advisors. Burland et al. (1977) describe a category of damage that is described in this paper as *disappointing* in that it spoils appearance and precedes *unserviceability*, which describes the rain or wind getting in or the doors or the machinery jamming, progressing to *safety hazard* - beyond which the building should be put in quarantine pending rebuilding.

There was ample evidence regarding the significance of foundation displacements during the time that limit state design (LSD) and load and resistance factor design (LRFD) codes were written, and reliability-based design (RBD) was being developed. Simpson et al. (1981) pointed out that structural engineers are often unsure about the confidence geotechnical engineers actually place on their predictions of ground deformations. Hence, deformation checks have been subjected to much less scrutiny than those relating to collapse. The reason may be that, until relatively recently, engineers had no access to validated soil-structure deformation mechanisms for the assessment of serviceability that were equivalent to the failure wedges and slip circles that permit practical assessments of collapse. This deficit will be addressed later in the paper.

Geotechnical Uncertainty

Bolton (1981) reviewed *system* and *parameter uncertainty* in geotechnical engineering. Essentially, *system uncertainty* arises because existing behavioural models are a poor fit with reality. For example, everyday geotechnical calculation models generally ignore all but the most obvious stratification and anisotropy, the pre-existing lateral earth pressures, and the process of excess pore water pressure generation and its partial drainage. In addition, as noted

previously, they usually address total soil failure, rather than structural deformation leading to unserviceability, which is by far the more common limit state encountered in practice.

Parameter uncertainty recognises that engineers cannot know precise values of all the engineering properties that should ideally be available as inputs into their design models; judgment and choice are required. Bolton (1981) pointed out that *system uncertainty* should never be assessed by statistical means which inevitably requires just that class of uncertainty to be eliminated (e.g., the biased penny in a tossing trial). He also opined that *parameter uncertainty* should generally be dealt with by the deterministic analysis of validated limit mechanisms, employing carefully selected worst-case values of parameters, rather than probability theory (Bolton 1981). However, as will be explored, others have taken a different view.

McMahon (1985) categorised six types of uncertainty that are encountered in geotechnical engineering (Table 2). Practitioners may attempt to deal with Type 3 uncertainties arithmetically, i.e., by using statistical and probabilistic thinking. However, other sources of uncertainty can only be reduced if researchers develop better failure models for use in design, if practitioners maintain up-to-date skills, if clients release sufficient money for adequate ground investigation and construction control, and if all project partners maintain open channels of communication.

Moreover, *engineering judgment* is essential even in purely technical aspects of the design process. In his Laurits Bjerrum memorial lecture, Peck (1980) states that “judgment is required to set up the right lines of scientific investigation, to select the appropriate parameters for calculations, and to verify the reasonableness of the results”. Petroski (1993) described *engineering judgment* as “the quality factor among those countless quantities that have come to dominate design in our postcomputer age ... [it] prevents mistakes, catches errors, detects flaws, and anticipates failure.”

Codes of practice clearly cannot remove the need for good judgment and skill in engineering practice, nor is exhaustive computation in the absence of such judgment any panacea. Burland (2008a and 2008b) attributed the following sentiment to Hugh Golder: “Any design that relies for its success on a precise calculation is a bad design”.

One way of reducing uncertainty is to make the final design contingent on the prediction and then observation of field performance during the early stages of construction, called the *observational method* (Peck 1969). Peck (1969) pointed out that the essential requirement for use of the observational method is a design that can be modified *during construction*, which has implications for the drafting of construction contracts. Application of this approach to decision making is made more feasible by recent advances in smart sensor technologies that promise cheap and reliable means to monitor the deformation of geotechnical structures such as tunnels (Bennett et al. 2010, Cheung et al. 2010 and Mohamad et al. 2010), piled foundations (Klar et al. 2006) and deep excavation works (Schwamb et al. 2014). The most salient advantage is that such deformation measurements directly address the degree to which performance requirements, such as those in Table 1, are being met.

GEOTECHNICAL FACTOR OF SAFETY

Factors and Codes

The factor of safety (FOS), also described as a *factor of uncertainty* (or a *factor of ignorance* e.g., Petroski 1994, p. 31) is a commonly used engineering term, but it is difficult for practitioners to define and justify. To this end, codes of practice are written with the intention to guide the engineer towards an appropriate factor of safety and thus to a safe design; they do this using various methodologies and philosophies.

Meyerhof (1970) defined the factor of safety as “the ratio of the resistance of the structure to the applied loads in order to ensure freedom from danger, loss or risks”. He then explained that “the magnitude of the safety factor required depends mainly on the reliability of the design data ...” as well as (amongst other things) the probability of failure, and the consequences of failure, should it occur (Meyerhof 1970). Terzaghi and Peck (1948) (in Article 53) stated: “First, the factor of safety of the foundation with respect to the breaking into the ground should not be less than 3, which is the minimum factor of safety customarily specified for the design of the superstructure. Second, the deformation of the base of the structure due to unequal settlement should not be great enough to damage the structure. There is no definite relation between the factor of safety with respect to breaking into the ground and the settlement.”

Terzaghi and Peck (1948) gave some classical values of safety factors for geotechnical engineering design (Table 3). Meyerhof (1995) referred to the factors from Terzaghi and Peck (1948) as “customary total factors of safety”. Today the values in Table 3 can be thought of as reference values that practicing engineers consider when performing design calculations and drafting codes of practice. In many cases, even if a limit state design method is used, engineers will still refer to an *equivalent factor of safety*.

When reviewing the use of a single factor of safety in geotechnical engineering, Simpson et al. (1981) concluded that it can produce “sensible results when material strength is the greatest uncertainty in the design”, or when it is applied as a load factor where loads are significantly more uncertain than material strength. Significant problems arise, however, when both strength and loads are uncertain. Kulhawy (2010) described global factors of safety as “misleading” because they are usually assigned without considering “(1) any other aspects of the design process, such as the loads and their evaluation, method of analysis (ie, design equation), extent and quality of site investigation, method of property evaluation (ie, how to

select the undrained shear strength), and (2) uncertainties in design, such as variations in the loads and material strengths, unforeseen in-situ conditions, inaccuracies in the design equations, and errors arising from poorly supervised construction.”

Limit State Design

Most structural and geotechnical codes are now based on limit-state design precepts. In consideration of limit state design, Simpson et al. (1981) stated that “its basis is the acknowledgement that a structure may fail to meet its design requirements through a number of possible shortcomings ...” Each of these shortcomings is described as a limit state (Simpson et al. 1981).

Phoon et al. (2003a) described the basic requirements of the limit state design philosophy as follows: “(1) identify all potential failure modes or limit states; (2) apply separate checks on each limit state; and (3) show that the occurrence of each limit state is sufficiently improbable”. Instead of simply invoking the good judgment of an experienced engineer, the third of these requirements was phrased by Phoon to imply that a probabilistic approach should be used, notwithstanding the philosophical objections with regard to system uncertainty and the practical difficulties afforded by the collection of data sufficient to make meaningful probability estimates. Recent drafters of limit-state design codes have attempted to overcome these potential hurdles by adopting a partial factor format, as explained subsequently.

Partial Factors

Instead of specifying a single factor of safety, a partial factor limit state code stipulates that certain parameters or calculated values are factored at various points in the design calculation. Such factors are specified by the code drafters. This approach recognises that the uncertainty

in the loading, for example, is likely to be different to the uncertainty in soil strength. According to Simpson (2000), “most schemes have therefore chosen to factor only some of the uncertain parameters, with the intention of giving a sufficient margin to cover those not factored.”

Meyerhof tracked the development of partial factors sets in geotechnical codes of practice for many years (e.g., Meyerhof 1970, Meyerhof 1984, Meyerhof 1994 and Meyerhof 1995). Table 4 provides a comparison of partial factor sets for various design approaches in codes of practice (Meyerhof 1995). Meyerhof (1984) noted that the minimum values of partial factors were obtained by calibration against traditional safety factors to ensure that designs under any new code would generally have the same safety margin than that had been deemed acceptable based on past experience. Code comparison of various codes of practice for simple bored pile design in London clay (Vardanega et al. 2012a, Vardanega et al. 2014) revealed that most codified approaches settled on an equivalent global factor of safety of approximately 2.5 (one notable exception being the Russian code). One possibility for future change is the adoption of RBD procedures, as proposed by, e.g., Phoon et al. (2003a, 2003b), taking into account the high values of the coefficient of variation (*COV*) that are observed for many geotechnical parameters. RBD will be discussed in more detail later in the paper.

Limit Modes

Consider the determination of the limit state criteria for the design of bridge abutment walls. Bolton (1989) offered five limit modes that qualitatively cover the full range of possible soil-structure behaviour situations that may arise: (1) “unserviceability through soil strain”; (2) “unserviceability through concrete deformation”; (3) “collapse through soil failure alone”; (4) “collapse with both soil and concrete failure”; and (5) “collapse arising without soil failure”.

Codes of practice should assist designers in understanding the limit modes that need to be investigated with the appropriate application of “worst credible” characteristic parameters (cf. Simpson et al 1981 and Bolton 1989). Bolton (1989) advocated limit state design thinking by summarising that “The code must offer specific guidance to the designer in the selection of worst credible characteristics for the soil-structure system, and the external influences acting on it: no further safety factor will then be necessary”.

This approach requires that the code guide the engineer to the critical parameter in each limiting mode and then offer guidance on selecting a worst credible value.

Both the methods of Simpson et al. (1981) and Bolton (1989) were criticised by Phoon et al. (2003a) being little better than the use of “empirical partial factors”. Bolton (1981) concluded that “deterministic calculations based on observable mechanisms offer a more reliable route to decision-making in geotechnical design than do the processes of statistical inference”. Statistical methods aid in sensitivity analyses, but they cannot be employed intelligently if the mechanism of failure is not well understood. In particular, the great majority of RBD approaches focus on ultimate failure, whereas the onset of excessive deformations leading to structural unserviceability is widely accepted to be a more critical issue in foundation engineering. Later in the paper the merging of the mechanistic and statistical design approaches will be reviewed.

Characteristic Values

Eurocode 7 Part 1 (CEN 2004) does not require designers to use reliability theory to determine soil properties but it does require the determination of a “characteristic value” of a soil parameter for use in design, which may be protected by an additional partial factor. Clauses 2.4.5.2 (1)P and (2)P of CEN (2004) state:

“(1)P The selection of characteristic values for geotechnical parameters shall be based on results and derived values from laboratory and field tests, complemented by well-established experience.

(2)P The characteristic value of a geotechnical parameter shall be selected as a cautious estimate of the value affecting the occurrence of the limit state.”

The code then goes on to state in Clause 2.4.5.2 (11) of CEN (2004):

“(11) If statistical methods are used, the characteristic value should be derived such that the calculated probability of a worse value governing the occurrence of the limit state under consideration is not greater than 5%.”

Orr (2000) attempted to quantify the “cautious estimate”, by advocating the method proposed by Schneider (1999), which calls for the construction of a characteristic design line offset from the average line through the data of relevant test results by a 0.5 standard deviation. Although this offers the designer a calculation methodology for the notional characteristic value, it evades a variety of statistical questions. Does the designer seek an estimate of the mean of the parent population (e.g., the cone penetration resistance to be used to calculate the shaft capacity of a pile), or an extreme value applicable to a small region (e.g., to predict end-bearing)? Would the same partial factor be applicable to both? And would the same value still apply if a more rigorous ground investigation acquired ten times as many data points? Or should the designer rationally be seeking a lower bound to the data rather a mean value (e.g., residual strength estimated after a variety of direct shear tests on cores recovered from a slope)? Selection of sensible fractiles for base and shaft resistances for bored pile design in stiff clay is studied in Vardanega et al. (2012c, 2013b).

STATISTICAL APPROACHES TO FAILURE ANALYSIS

Probability Distributions

Meyerhof (1970) highlighted the obvious point that safety factors cannot imply “absolute” safety and “include a small acceptable risk” of failure. Following the terminology from Phoon et al. (2003a), consider a load distribution (F) with a mean value (m_F) and the resistance (capacity) distribution (Q) with an average value (m_Q): the area enclosed by the two curves represents instances in which $Q < F$ and corresponds to the probability of failure. If the shapes of the curves are known, then the value p_f , i.e., the probability of failure, can be estimated.

However, in geotechnical works especially, it is difficult to determine the shapes of the frequency distributions (e.g., Bolton 1993). Furthermore, the consequences of failure are likely to be perceived as an unserviceability of the structure concerned rather than a collapse, because there are likely to be earlier signs in the form of surprising displacements which result in temporary measures such as limiting live loads until underpinning can be provided to foundations. This, of course, is not to underestimate the importance for designers to assure that structures fulfill their intended purpose while maintaining the planned budget. However, it does alter the perception of the consequences of failure, and emphasises the importance to the designer of assuring ductility and continuity, and excluding brittle failures, regardless of the smallness of the notional probability of failure.

Scott et al. (2003) argued that “in geotechnical engineering, information about the mean and variance of a load or resistance is typically available, even though the exact distribution may not be known”. In their review, Scott et al. (2003) argued that although the assumption of a normal distribution is the “least biased” choice, the log-normal distribution is often favoured as factors such as, load magnitudes “cannot take negative values” (although Lumb 1970 did point out that other distributions could be used to satisfy the aforementioned requirement).

Heterogeneity

A major aspect of geotechnical engineering is to capture and model the distribution of soil parameters, which generally vary with depth (Phoon and Kulhawy 1999) because strength and stiffness each vary with mean effective stress. Vanmarcke (1977) identified three causes of uncertainty in choosing a design soil strength profile: (1) natural heterogeneity of the soil, (2) lack of subsurface soil data and (3) errors arising during testing (i.e., measurement). Christian et al. (1994) expressed these three sources of error in terms that would be familiar to every application of signal processing, namely, “systematic error” and “data scatter” (Figure 1). Statistical methods of data analysis can correspondingly assist in the construction of soil property profiles on site (e.g., Whitman 2000). Practicing engineers may, however, prefer less formal procedures. Duncan (2000) reviewed the “graphical three-sigma rule” that can be used to estimate an appropriate design line to describe the variation of a soil parameter with depth.

RELIABILITY-BASED DESIGN

Probability of Failure

Reliability and probabilistic thinking for geotechnical design (e.g., Freudenthal 1947, Kulhawy 2010) has found use in many geotechnical design applications e.g., shallow foundation capacity (Phoon et al. 2003a, 2003b and Foye et al. 2006a, 2006b), capacity of deep foundations (Zhang et al. 2001), settlement of foundations (Akbas and Kulhawy 2009) and random-parameter finite-element methods (Schweiger 2001). If the probability of failure, which is the probability of failing to meet at least one performance requirement, is p_f , then the reliability of the system is said to be r_f where:

$$r_f = 1 - p_f \quad (1)$$

Reliability then represents the probability that the system will perform as intended.

Reliability Index

Cornell (1969), Phoon et al. (2003a), Scott et al. (2003), Kulhawy (2010) and Ebrahimian and De Risi (2014) all provide definitions for the reliability index. Engineers generally consider the definition of load (F), and capacity (Q), which allows the formal definition of failure as the condition $Q \leq F$. However, the *safety margin formulation* can be expressed more generally as a *limit state function* (or *performance function*) $V = R - L$ where R is a generalized estimate of capacity (or resistance) and L is a generalized loading function. The probability of failure p_f can be then defined according to equation (2) as the probability that the limit state function V is lower than or equal to zero. The definition of p_f leads to the formal and generalized definition of a reliability index, typically referred to as β in the literature, and in this paper referred to as RI (to avoid confusion with other variables indicated by the same symbol), [equation (3)], where $\Phi(\cdot)$ is the standard normal cumulative distribution function (CDF). Equation (3), however, does not “imply that uncertain parameters are jointly normal” (Ebrahimian and De Risi 2014) and then that “the inverse of the standard normal CDF simply provides a convenient one-to-one mapping between the computed probability of failure and a reliability index” (see Ebrahimian and De Risi 2014 for more details).

$$p_f = P[V \leq 0] \quad (2)$$

$$\beta = RI = -\Phi^{-1}(p_f) \quad (3)$$

Cornell Index

The basic form of the reliability index was proposed by Cornell (1969), in which RI (β) is defined as shown in Equation (4) and is also called the “Cornell index” (Ebrahimian and De Risi 2014). If F and Q are normally distributed, RI can be defined according to the expression provided in equation (4), in which m_V is the mean of the probability distribution of the safety margin (also normally distributed if F and Q are normally distributed); s_V is the standard

deviation of the safety margin; m_Q is the mean value of computed capacity; m_F is the mean value of estimated load; s_Q is the standard deviation of computed capacity; and s_F is the standard deviation of estimated load (e.g., Phoon et al. 2003a).

$$\beta = RI = \frac{m_Q - m_F}{(s_Q^2 + s_F^2)^{0.5}} = \frac{m_V}{s_V} \quad (4)$$

The work of Lumb (1966, 1970) showed that although other distributions may better fit data of soil strength (for the Hong Kong soils he studied), the simplifying assumption of a normal distribution is also acceptable in the central region of the data. Unfortunately, this rules out its application to extreme values $RI > 2$, which is exactly where reliability estimates are currently employed.

Challenges for RBD in Geotechnical Applications

RBD is a method to deal with Type 3 uncertainties in geotechnical engineering practice (Table 2). Some challenges to be faced in applying RBD even in this restricted class of uncertainty are listed as follows:

- Knowledge of the shapes of the distributions (e.g., log-normal, normal, beta) of soil properties is, by definition, impossible to obtain at the tails. Therefore, any required inference of extreme values, beyond the predictive limits of whatever data have been encountered on site, would have to appeal to some wider regional experience of severe deviations. This caveat is likely to include all the acceptable performances listed in Table 1;
- Although reliable estimates of the mean and standard deviation are easier to ascertain than the shapes of the pdfs, there remains an unjustified tendency to rely solely on published COV values from other soil deposits. Because variability in a soil deposit is a function of the processes of geological deposition and geomorphological change that have influenced the site (e.g., Hutchinson 2001), intensive efforts would be necessary to draw parallels between a new

site that lacks such information and previously explored sites for which COV values have been established;

- The spatial autocorrelation of geotechnical properties is known to be significant, but difficult to ascertain because of sparse sampling. Once again, geological interpretation and experience is required to set reasonable intervals for boring and sampling in relation to consistencies and inconsistencies expected at a site. Engineers should realise that the probability of failure of an end-bearing pile is intimately linked with the probability that an erratic soft spot greater than the diameter of the pile may be located below its base. Furthermore, if e.g., Prandtl's model is used for bearing capacity calculations on heterogeneous clay, any single estimate of soil strength must bias the calculated reliability. If, for example, the designer attributes the worst credible strength to the whole mechanism, that should lead to an overestimate of the probability of failure; and

- With very few exceptions, RBD is applied to the ultimate failure of the soil, rather than to the onset of disappointing deformations that later develop into serviceability issues, and then ultimately threaten structural collapse only if nothing has been done to interrupt the loading process or enhance the soil-foundation system. In that sense, the rigid demarcation between serviceability limit state (SLS) and ultimate limit state (ULS) failures in limit state design is unrealistic and unhelpful for a designer wishing to apply risk-based concepts. Predicting displacements, placing realistic bounds on those predictions, and comparing those bounds with displacement limits such as those described in Table 1 would offer a more objective approach. The challenge for geotechnical practitioners is not only to make settlement predictions, but to do so within a rigorous statistical framework. For this purpose it would be essential to use a soil constitutive model with a minimum number of parameters, to have access to a database that indicates the variability of those parameters, and to insert

them in a robust but simple deformation mechanism that has been calibrated against observed performance. These elements will now be explained in more detail.

SOIL DEFORMABILITY

Phoon and Kulhawy (1999) demonstrated the significance of the coefficient of variation for use in RBD. Subsequent papers (e.g., Ching and Phoon 2014a, 2014b) focussed on the determination of the coefficient of variability, primarily for strength and index parameters. Kulhawy and Mayne (1990) championed the use of geo-databases for parameter selection. Recent papers detailing the variation of deformation parameters in new databases are summarised subsequently.

Small Strain Stiffness

The importance of small strain stiffness for geotechnical design is mentioned in Burland (1989) and Atkinson (2000). Ideally, G_{max} should be measured on site (e.g., Clayton 2011 and Stokoe et al. 2011). Predicting G_{max} simply from density and mean effective stress may lead to errors of up to a factor of 2 (Vardanega and Bolton 2013). However, modified hyperbolae can be used to make a-priori estimates of soil stiffness reduction. Vardanega and Bolton (2013, 2014) presented a database of 67 modulus reduction curves of a large variety of fine-grained soils. Using the form of the equation used by Darendeli (2001) and Zhang et al. (2005), the variability of γ_{ref} (which is the shear strain required to reduce G/G_{max} to 0.5) and α was determined. The reference strain (γ_{ref}) was shown to correlate strongly with plasticity index whereas α in equation 5 could not usefully be correlated with any other parameter. The database of tests on sands reported in Oztoprak and Bolton (2013) showed that α is correlated

to the coefficient of uniformity and γ_{ref} related to the mean effective stress, uniformity coefficient, void ratio and relative density.

$$\frac{G}{G_{max}} = \frac{1}{\left(1 + \left[\frac{\gamma}{\gamma_{ref}}\right]^{\alpha}\right)} \quad (5)$$

Predicting G/G_{max} using versions of equation 5 (Oztoprak and Bolton 2013 and Vardanega and Bolton 2013) results in errors of up to a factor of 1.3; approaches such as these run outside the main body of available data at approximately 0.5% strain. Assessing the deformability of clays at higher strains requires an alternative approach.

Mobilization of Moderate Strengths in Clay

Vardanega and Bolton (2011, 2012) demonstrated, through a database of 115 diverse stress-strain tests on natural cores taken from 19 contrasting fine grained soils, that the mobilization of shear stress τ with shear strain γ in an undrained shear test taken up to peak shear strength c_u , offers a tight fit to the power law expression:

$$\frac{\tau}{c_u} = 0.5 \left(\frac{\gamma}{\gamma_{M=2}}\right)^b \quad 0.2 < \frac{\tau}{c_u} < 0.8 \quad (6)$$

This represents a two-parameter constitutive model for clays at moderate strains, tested from an initially isotropic stress state, and applicable only within the typical range of mobilization factor M (generally referred to as a safety factor in current geotechnical practice)

$$M = \frac{c_u}{\tau} \quad 5 > M > 1.25 \quad (7)$$

This is reminiscent of expressions for soil stress-strain used in the development of p-y curves that make use of ε_{50} (e.g., Matlock 1970). However, in the earlier work, evidence of high quality tests in the databases was not apparent, nor the recognition that the exponent b is a significant source of variability.

The key parameter is the mobilization strain $\gamma_{M=2}$, which is the shear strain mobilized at half the shear strength, i.e., at $M = 2$. Vardanega et al. (2012b, 2013a) demonstrated that $\gamma_{M=2}$ can

range over an order of magnitude, from approximately 0.4% for a normally consolidated kaolin to approximately 4% for a heavily overconsolidated kaolin. However, it is also known that soils are inherently anisotropic, so it must be anticipated that $\gamma_{M=2}$ would vary between triaxial compression and extension, for example. To verify a serviceability requirement, it is essential that soil test data be used to obtain appropriate values of $\gamma_{M=2}$. If this requirement is ignored, and designers continue to rely only on the setting of a partial factor on strength, it is self-evident that strains in service will vary from soil to soil by at least the same factor of 10 that is found for $\gamma_{M=2}$. Serviceability criteria will either be grossly overconservative, or will fail to safeguard against structural damage, depending on the soil concerned.

The second parameter in equation (6) is the exponent b , which was generally found to vary within a narrow range of approximately 0.3 to 0.7 for most soils (Vardanega and Bolton 2011). In general, a lower value of approximately 0.3 to 0.4 was obtained for normally consolidated clays that were sampled and set up in an isotropic stress state (Vardanega et al. 2012b and Bolton et al. 2014). A higher value of about 0.5 to 0.6 fitted the data of overconsolidated kaolin (Vardanega et al. 2012b), and 0.6 also coincided with the mean value obtained for the 19 natural clays and silts analysed in Vardanega and Bolton (2011). If it is assumed that $b = 0.6$, but a value is obtained for $\gamma_{M=2}$, the fitting of the power curve equation (6) generally succeeds in capturing the strain data in Vardanega and Bolton's databases within a factor of 2.

Statistics describing the variability of clays included in Vardanega and Bolton's databases are summarised in Table 5. Obviously, the more data that are obtained for a given clay of interest, the more accurate the curve fitting could be. The in situ earth pressure coefficient inevitably influences subsequent stress-strain behaviour in the ground. Although Osman and Bolton (2005) showed that a field trial of footing behaviour could be predicted adequately by using the average stress-strain curve from K_0 -consolidated triaxial compression and extension

tests on good quality core samples, the influence of K_0 in other applications may not be summarised so conveniently. At least equation (6), through the two deformation parameters $\gamma_{M=2}$ and b with values fitted to the data of project-specific soil tests, provides a basis for ground displacement predictions that can be calibrated subsequently against field measurements.

DESIGN TO LIMIT DEFORMATIONS

Mobilizable Strength Design

If the deformability of soil can be predicted within given error bounds, only the pertinent ground deformation mechanism is required before structural displacements can be predicted and compared with safety and serviceability criteria, such as those listed in Table 1.

Mobilizable strength design (MSD) first emerged as a concept in relation to the displacements observed around stiff in situ retaining walls. Bolton and Powrie (1988) (Figure 2) and Bolton et al. (1990) invoked separate, but arguably consistent, mechanisms to describe the state of equilibrium around an embedded wall, and a distribution of soil displacements and strains consistent with the kinetics of a rigid wall, in undrained clay.

These two mechanisms were linked through the representative shear stress-strain relation of the clay. A permitted wall rotation could be converted into a kinematically equivalent permitted soil shear strain, which could in turn be translated using stress-strain data into a mobilizable soil strength, which could then be used to derive an appropriate embedded depth required for equilibrium. The method was validated through centrifuge models of simulated excavation one side of a stiff preformed wall.

Later, the same approach was used by Osman and Bolton (2004) to calibrate MSD against the non-linear finite element analysis (FEA) of retaining walls of various flexibility, subjected to excavation to various proportional depths, in clays that began with various K_0

values and that required different strains to reach failure. Wall displacements predicted by rigid-wall MSD, as a ratio of those computed by FEA, were shown to fall in the range 1.0 to 0.5, depending on the system parameters mentioned previously. The influences of these parameters on the calculated displacement ratio $\Delta_{\text{MSD}}/\Delta_{\text{FEA}}$ were, in descending order of significance: relative wall flexibility, embedment ratio, soil mobilization strain, and initial K_0 value. Designers who were able to apply the simple MSD approach could then use the charts in Osman and Bolton (2004) to recalibrate the MSD approximations accordingly.

An even simpler approach and suitable for *codes of practice* would be to work on the conservative side of the evaluations. If an in situ wall were to be designed with sufficient embedment to restrict wall rotations to 1/100, for example, a limit of 1/200 would be imposed in an equivalent MSD calculation, which offers the least favourable assessment of $\Delta_{\text{MSD}}/\Delta_{\text{FEA}}$ across the range of conditions considered by Osman and Bolton (2004). In conducting that calculation, the shear stress-strain curves would then be constructed based on a mean strength profile, a mobilization strain $\gamma_{M=2}$ obtained from the samples taken approximately from mid-depth of the wall, and by assuming a power index of $b = 0.6$. The consequences of the strength profile falling below the mean of the test data, the mobilization strain being larger, or the power exponent different from 0.6, could be investigated.

MSD was extended by Osman and Bolton (2006) to predict the lateral bulging of a braced wall supporting an excavation in clay, using the deformation mechanism shown in Figure 3. Lam and Bolton (2011) later developed a refined approach using an energy balance on the same mechanism as the key to the calculation method. Bolton et al. (2014) used this technique to present MSD-based design charts for deep excavations in Shanghai soil deposits, validated against a database of field construction records. The scatter evident in the field data is a good indication of the uncertainty inherent in making design assumptions, especially, to the extent of the ground deformation mechanism defined by the elevation below which wall and soil

displacements would be negligible. A good engineer in the possession of both field data from previous works and a simplified design rule, is well-placed to cope with such uncertainties.

Chart Methods

Bolton et al. (2014) demonstrated the use of new dimensionless groups to display wall bulging estimates, namely, the modified displacement factor ψ^* and the modified system stiffness η^* (equations 8 and 9) for the development of MSD-inspired design charts for use in Shanghai, which represented an advance on the traditional approach of Clough et al (1989). Figure 4 shows the clear division between deeper and shallower excavations for the field data available. Figure 4 shows design lines that capture the variation ψ^* and η^* using full MSD analysis (Lam and Bolton 2011) and with upper, middle, and lower bound profiles of undrained strength variation with depth, approximated for Shanghai in Bolton et al. (2014). The MSD calculation shows that a considerable increase in system stiffness is needed to effect a significant change in bulging displacement, and that improving soil undrained shear strength (such as by deep cement mixing) should be considerably more influential.

$$\eta^* = \frac{EI}{\gamma_w \lambda^4} \quad (8)$$

$$\psi^* = \frac{2w_{max}}{\lambda_{average} \gamma_{M=2}} = \left(\frac{2}{M}\right)^{1/b} \quad (9)$$

Full MSD Predictions with RBD

Zhang et al. (2015) applied the MSD method from Osman and Bolton (2004) to a database of 45 field case histories and 14 centrifuge tests of unpropped cantilever wall displacements. They determined that the correction factor (FEA/MSD) is related to six dimensionless groups, and that the residual random part can be treated as a lognormal random variable. This study demonstrates the potential for MSD to be used in a RBD context.

SUMMARY REMARKS

The Type 2 uncertainty described by McMahon (1985), the risk of designing to the wrong failure mechanism, is overlooked by most codified geotechnical design approaches, or not given the prominence it deserves. Many codes of practice have not emphasised the importance of the prediction of settlements as the key geotechnical element governing most structural design works. Furthermore, most of the highly cited studies on RBD assume that the geotechnical engineer is only concerned with gross collapse. Ground displacements should, however, be at the forefront of design thinking. To achieve this, deformation mechanisms need to be understood, and reliable values of tolerable settlements defined. The MSD philosophy provides geotechnical engineers with the tools to better calculate ground deformations without resorting to complex numerical methods. Recent databases have been produced that can be expanded and further analysed to provide statistical measures for RBD.

ACKNOWLEDGEMENTS

The first author wishes to thank his colleague, Dr Flavia De Luca from the University of Bristol, for her helpful advice and discussions relating to reliability theory, and especially for her help with the section that discusses the reliability index. The authors also wish to thank the anonymous reviewers of the paper for their helpful comments and suggestions that have assisted with improving the paper.

NOTATION

The following symbols are used in this paper:

b = non-linearity factor (soil);

c = cohesion;

c_u = undrained shear strength;
 EI = flexural rigidity per unit width of a retaining wall;
 F = load distribution;
 G = secant shear modulus;
 G_{max} = shear stiffness at very small strains;
 K_0 = coefficient of earth pressure at rest;
 L = generalised loading function;
 M = mobilisation factor;
 m_F = mean value of estimated load;
 m_Q = mean value of computed capacity;
 m_V = mean value of the safety margin;
 pf = probability of failure;
 Q = computed capacity (resistance) distribution;
 s_F = standard deviation of estimated load;
 s_Q = standard deviation of computed capacity;
 s_V = standard deviation of the performance function;
 R = generalised estimate of capacity (resistance);
 RI = reliability index;
 r_f = system reliability;
 V = performance function;
 w = overall settlement;
 w_{max} = maximum measured wall bulge;
 α = curvature parameter;
 β = angular distortion (or relative rotation);
 γ = shear strain;
 $\gamma_{M=2}$ = shear strain to mobilise 50 per cent undrained shear strength;

γ_{ref} = reference shear strain;
 γ_w = unit weight of water;
 $\Delta w/L$ = relative deflection;
 ε_{50} = strain to mobilise 50 per cent strength;
 η^* = modified system stiffness;
 θ = tilt (local and overall);
 λ = wavelength of the wall deformation mechanism;
 $\lambda_{average}$ = average of the wavelength of the wall deformation mechanism;
 μ = mean value;
 σ = standard deviation;
 τ = mobilised shear strength;
 ψ^* = modified displacement factor;
 ϕ = soil friction angle;
 $\Phi(\cdot)$ = standard normal cumulative distribution function.

REFERENCES

- Akbas, S. O. and Kulhawy, F. H. (2009). "Reliability-Based Design Approach for Differential Settlement of Footings on Cohesionless Soils." *Journal of Geotechnical and Geoenvironmental Engineering*, **135(12)**: 1779-1788.
[http://dx.doi.org/10.1061/\(ASCE\)GT.1943-5606.0000127](http://dx.doi.org/10.1061/(ASCE)GT.1943-5606.0000127)
- Atkinson, J. H. (2000). "Non-linear soil stiffness in routine design." *Géotechnique*, **50(5)**: 487-508. <http://dx.doi.org/10.1680/geot.2000.50.5.487>
- Bennett, P. J., Kobayashi, Y., Soga, K. and Wright, P. (2010). "Wireless sensor network for monitoring transport tunnels." *Proceedings of the Institution of Civil Engineers -*

Geotechnical Engineering, **163(3)**: 147-156.

<http://dx.doi.org/10.1680/geng.2010.163.3.147>

Bolton M. D. (1981). "Limit state design in geotechnical engineering." *Ground Engineering*, **14(6)**: 39-46.

Bolton, M. D. (1989). "The development of codes of practice for design." *Proceedings of the Twelfth International Conference on Soil Mechanics and Foundation Engineering*, Rio de Janeiro 13-18 August 1989, vol. 3, A.A. Balkema, Rotterdam, Netherlands, 2073-2076.

Bolton, M. D. (1993). "What are partial factors for?" *Proceedings International Symposium on Limit State Design in Geotechnical Engineering Copenhagen 3rd May 1993*, Danish Geotechnical Society, 565-583.

Bolton, M. D., Lam, S.-Y., Vardanega, P. J., Ng, C. W. W. and Ma, X. (2014). "Ground Movements due to deep excavations in Shanghai: Design charts." *Frontiers of Structural and Civil Engineering*, **8(3)**: 201-236. <http://dx.doi.org/10.1007/s11709-014-0253-y>

Bolton, M. D. and Powrie, W. (1988). "Behaviour of diaphragm walls in clay prior to collapse." *Géotechnique*, **38(2)**: 167-189. <http://dx.doi.org/10.1680/geot.1988.38.2.167>

Bolton, M. D., Springman, S. M. and Sun, H. W. (1990). "The behaviour of bridge abutments on clay." *Proceedings ASCE Conference on Design and Performance of Earth Retaining Structures June 18-21 Cornell University Ithaca New York*, Lambe, P. C. and Hansen, L. A. (eds.), American Society of Civil Engineers, 292-306.

Boscardin, M. D. and Cording, E. J. (1989). "Building response to excavation-induced settlement." *Journal of Geotechnical Engineering*, **115(1)**: 1-21.

[http://dx.doi.org/10.1061/\(ASCE\)0733-9410\(1989\)115:1\(1\)](http://dx.doi.org/10.1061/(ASCE)0733-9410(1989)115:1(1))

Burland, J. B. (1989). "Ninth Laurits Bjerrum Memorial Lecture: "Small is beautiful" – the stiffness of soils at small strains." *Canadian Geotechnical Journal*, **26(4)**: 499-516.

<http://dx.doi.org/10.1139/t89-064>

- Burland, J. B. (2008a). “Reflections on Victor de Mello, Friend, Engineer and Philosopher.” *Soils and Rocks*, São Paulo, **31(3)**: 111-123.
< <http://victorfbdemello.com.br/arquivos/Lectures/Victor%20de%20Mello%20Lecture-J%20Burland-published%20at%20Soils%20and%20Rocks.pdf> > (Sept. 10, 2015).
- Burland, J. B. (2008b). “The founders of Geotechnique.” *Géotechnique*, **58(5)**: 327-341.
<http://dx.doi.org/10.1680/geot.2008.58.5.327>
- Burland, J. B., Broms, B. B. and DeMello, V. F. B. (1977). “Behaviour of foundations and structures.” *Proceedings Ninth International Conference Soil Mechanics and Foundation Engineering Tokyo July 10 – 15 1977*, vol. 2, Japanese Society for Soil Mechanics and Foundation Engineering, Tokyo, 495-546.
- Burland, J. B., Mair, R. J. and Standing, J. R. (2004). “Ground performance and building response due to tunnelling.” *Advances in Geotechnical Engineering: The Skempton Conference*, R. J. Jardine, D. M. Potts and K. G. Higgins (eds.), vol. 1, Thomas Telford, London, U.K., 291-342.
- Burland, J. B. and Wroth, C. P. (1975). “Allowable and differential settlements of structures.” *Settlements of Structures: conference organised by the British Geotechnical Society at the Lady Mitchell Hall, Cambridge*, Pentech Press, London, 611-654.
- CEN (2004). Eurocode 7: Geotechnical design - Part 1: General rules, EN 1997-1:2004, November 2004, European Committee for Standardization, Brussels, Belgium.
< <https://law.resource.org/pub/eu/eurocode/en.1997.1.2004.pdf> > (Sept. 10, 2015).
- Cheung, L. L. K., Soga, K., Bennett, P. J., Kobayashi, Y., Amatya, B. and Wright, P. (2010). “Optical fibre strain measurement for tunnel lining monitoring.” *Proceedings of the Institution of Civil Engineers - Geotechnical Engineering*, **163(3)**: 119-130.
<http://dx.doi.org/10.1680/geng.2010.163.3.119>

- Ching, J. and Phoon, K.-K. (2014a). “Correlations among some clay parameters – the multivariate distribution.” *Canadian Geotechnical Journal*, **51(6)**: 686-704.
<http://dx.doi.org/10.1139/cgj-2013-0353>
- Ching, J. and Phoon, K.-K. (2014b). “Transformations and correlations among some clay parameters – the global database.” *Canadian Geotechnical Journal*, **51(6)**: 663-685.
<http://dx.doi.org/10.1139/cgj-2013-0262>
- Christian, J. T., Ladd, C. C., and Baecher, G. B. (1994). “Reliability applied to slope stability analysis.” *Journal of Geotechnical Engineering*, **120(12)**: 2180-2207.
[http://dx.doi.org/10.1061/\(ASCE\)0733-9410\(1994\)120:12\(2180\)](http://dx.doi.org/10.1061/(ASCE)0733-9410(1994)120:12(2180))
- Clayton, C. R. I. (2011). “Stiffness at small strain: research and practice.” *Géotechnique*, **61(1)**: 5-37. <http://dx.doi.org/10.1680/geot.2011.61.1.5>
- Clough, G. W., Smith, E. M., and Sweeney, B. P. (1989). “Movement control of excavation support systems by iterative design.” *Proceedings ASCE Foundation Engineering: Current Principles and Practice*, vol. 2, ASCE, New York, 869–884.
- Cornell, C. A. (1969). A Probability-based structural code. *ACI Journal*, **66(12)**: 974–985
- Darendeli, M. B. (2001). “Development of a new family of normalized modulus reduction and material damping curves.” Ph.D. thesis, University of Texas at Austin, TX.
- Duncan, J. M. (2000). “Factors of Safety & Reliability in Geotechnical Engineering.” *Journal of Geotechnical and Geoenvironmental Engineering*, **126(4)**: 307-316.
[http://dx.doi.org/10.1061/\(ASCE\)1090-0241\(2000\)126:4\(307\)](http://dx.doi.org/10.1061/(ASCE)1090-0241(2000)126:4(307))
- Ebrahimian, H. and De Risi, R. (2014). “Seismic Reliability Assessment, Alternative Methods for.” In: *Encyclopedia of Earthquake Engineering* (Beer, M., Kouglioutzoglou, I. A., Patelli, E. and Au I. S.-K. eds.), Springer Berlin Heidelberg, http://dx.doi.org/10.1007/978-3-642-36197-5_245-1

- Foye, K. C., Salgado, R. and Scott, B. (2006a). "Assessment of Variable Uncertainties for Reliability-Based Design of Foundations." *Journal of Geotechnical and Geoenvironmental Engineering*, **132(9)**: 1197-1207.
[http://dx.doi.org/10.1061/\(ASCE\)1090-0241\(2006\)132:9\(1197\)](http://dx.doi.org/10.1061/(ASCE)1090-0241(2006)132:9(1197))
- Foye, K. C., Salgado, R. and Scott, B. (2006b). "Resistance Factors for Use in Shallow Foundation LFRD." *Journal of Geotechnical and Geoenvironmental Engineering*, **132(9)**: 1208-1218. [http://dx.doi.org/10.1061/\(ASCE\)1090-0241\(2006\)132:9\(1208\)](http://dx.doi.org/10.1061/(ASCE)1090-0241(2006)132:9(1208))
- Freudenthal, A. (1947). "Safety of Structures." *Transactions of the ASCE*, **112**: 125-180.
- HMSO (1967) "Report of the Tribunal appointed to inquire into the Disaster at Aberfan on October 21st 1966." Davies, H. E. (Lord Justice, chairman), H.L. 316, H.C. 553, Her Majesty's Stationery Office, London, United Kingdom.
- Hutchinson, J. N. (2001). "Reading the Ground: Morphology and Geology in Site Appraisal." *Quarterly Journal of Engineering Geology and Hydrogeology*, **34(1)**: 7-50.
<http://dx.doi.org/10.1144/qjegh.34.1.7>
- Klar, A., Bennett, P. J., Soga, K., Mair, R. J., Tester, P., Fernie, R., St John, H. D. and Torp-Peterson, G. (2006). "Distributed strain measurement for pile foundations." *Proceedings of the Institution of Civil Engineering: Geotechnical Engineering*, **159(3)**: 135-144.
<http://dx.doi.org/10.1680/geng.2006.159.3.135>
- Kulhawy, F. H. (2010). "Uncertainty, Reliability, and Foundation Engineering: The 5th Peter Lumb Lecture." *The Hong Kong Institution of Engineers Transactions*, **17(3)**: 19-24.
- Kulhawy, F. H. and Mayne, P. W. (1990). "Manual on estimating soil properties for foundation design." *Rep. No. EL-6800*, Electric Power Research Institute, Palo Alto, California.
- Lam, S. Y. and Bolton, M. D. (2011). "Energy conservation as a principle underlying mobilizable strength design for deep excavations." *Journal of Geotechnical and*

Geoenvironmental Engineering, **137(11)**: 1062-1074.

[http://dx.doi.org/10.1061/\(ASCE\)GT.1943-5606.0000510](http://dx.doi.org/10.1061/(ASCE)GT.1943-5606.0000510)

Leonards, G. A. (1982). "Investigation of failures." *Journal of the Geotechnical Engineering Division*, **108(2)**: 187-246.

Lumb, P. (1966). "The variability of natural soils." *Canadian Geotechnical Journal*, **3(2)**: 74-97. <http://dx.doi.org/10.1139/t66-009>

Lumb, P. (1970). "Safety factors and the probability distribution of soil strength." *Canadian Geotechnical Journal*, **7(3)**: 225-242. <http://dx.doi.org/10.1139/t70-032>

Matlock, H. (1970). "Correlations for design of laterally loaded piles in soft clay." *Proceedings of the 2nd Annual Offshore Technology Conference*, OTC Paper 1204, Offshore Technology Conference, Dallas, Tx, 577-594. <http://dx.doi.org/10.4043/1204-MS>

McMahon, B. K. (1985). "Geotechnical Design in the face of uncertainty." *Australian Geomechanics Journal*, **10(1)**: 7-19.

Meyerhof, G. G. (1953). "Some recent foundation research and its application to design." *Structural Engineering*, **31(6)**: 151-167.

Meyerhof, G. G. (1970). "Safety factors in soil mechanics." *Canadian Geotechnical Journal*, **7(4)**: 349-355. <http://dx.doi.org/10.1139/t70-047>

Meyerhof, G. G. (1982). "Limit states design in geotechnical engineering." *Structural Safety*, **1(1)**: 67-71. [http://dx.doi.org/10.1016/0167-4730\(82\)90015-7](http://dx.doi.org/10.1016/0167-4730(82)90015-7)

Meyerhof, G. G. (1984). "Safety factors and limit states analysis in geotechnical engineering." *Canadian Geotechnical Journal*, **21(1)**: 1-7. <http://dx.doi.org/10.1139/t84-001>

Meyerhof, G. G. (1994). "Evolution of safety factors and geotechnical limit state design." *The Second Spencer J. Buchanan Lecture*, 4 November, Texas A&M University, TX.

< <https://ceprofs.civil.tamu.edu/briaud/buchanan%20web/Second%20Buchanan%20Lecture.pdf> > (Oct. 26, 2015).

- Meyerhof, G. G. (1995). "Development of Geotechnical Limit State Design." *Canadian Geotechnical Journal*, **32(1)**: 128-136. <http://dx.doi.org/10.1139/t95-010>
- Mohamad, H., Bennett, P. J., Soga, K., Mair, R. J. and Bowers, K. (2010). "Behaviour of an old masonry tunnel due to tunnelling-induced ground settlement." *Géotechnique*, **60(12)**: 927-938. <http://dx.doi.org/10.1680/geot.8.P.074>
- Morley, J. (1996). " "Acts of God": The Symbolic & Technical Significance of Foundation Failures." *Journal of Performance of Constructed Facilities*, **10(1)**: 23-31. [http://dx.doi.org/10.1061/\(ASCE\)0887-3828\(1996\)10:1\(23\)](http://dx.doi.org/10.1061/(ASCE)0887-3828(1996)10:1(23))
- Orr, T. L. L. (2000). "Selection of characteristic values and partial factors in geotechnical designs to Eurocode 7." *Computers and Geotechnics*, **26(3-4)**: 263-279. [http://dx.doi.org/10.1016/S0266-352X\(99\)00042-7](http://dx.doi.org/10.1016/S0266-352X(99)00042-7)
- Osman, A. S. and Bolton, M. D. (2004). "A new design method for retaining walls in clay." *Canadian Geotechnical Journal*, **41(3)**: 451-466. <http://dx.doi.org/10.1139/t04-003>
- Osman, A.S. and Bolton, M.D. (2005). "Simple plasticity-based prediction of the undrained settlement of shallow circular foundations on clay." *Géotechnique*, **55(6)**: 435-447. <http://dx.doi.org/10.1680/geot.2005.55.6.435>
- Osman, A. S. and Bolton, M. D. (2006). "Ground movement predictions for braced excavations in undrained clay." *Journal of Geotechnical and Geoenvironmental Engineering*, **132(4)**: 465-477. [http://dx.doi.org/10.1061/\(ASCE\)1090-0241\(2006\)132:4\(465\)](http://dx.doi.org/10.1061/(ASCE)1090-0241(2006)132:4(465))
- Oztoprak, S. and Bolton, M. D. (2013). "Stiffness of sands through a laboratory test database." *Géotechnique*, **63(1)**: 54-70. <http://dx.doi.org/10.1680/geot.10.P.078>

- Peck, R. B. (1969). "Advantages and limitations of the observational method in applied soil mechanics." *Géotechnique*, **19(2)**: 171-187. <http://dx.doi.org/10.1680/geot.1969.19.2.171>
- Peck, R. B. (1980). "“Where has all the judgment gone?” The fifth Laurits Bjerrum memorial lecture." *Canadian Geotechnical Journal*, **17(4)**: 584-590. <http://dx.doi.org/10.1139/t80-065>
- Peck, R. B. and Bryant, F. G. (1953). "The Bearing Capacity Failure of the Transcona Elevator." *Géotechnique*, **3(5)**: 201-208. <http://dx.doi.org/10.1680/geot.1953.3.5.201>
- Petroski, H. (1993). "Failure as Source of Engineering Judgment: Case of John Roebling." *Journal of Performance of Constructed Facilities*, **7(1)**: 46-58. [http://dx.doi.org/10.1061/\(ASCE\)0887-3828\(1993\)7:1\(46\)](http://dx.doi.org/10.1061/(ASCE)0887-3828(1993)7:1(46))
- Petroski, H. (1994). *Design Paradigms: Case Histories of Error and Judgment in Engineering*. Cambridge University Press, United Kingdom.
- Phoon, K. and Kulhawy, F. H. (1999). "Characterisation of geotechnical variability." *Canadian Geotechnical Journal*, **36(4)**: 612-624. <http://dx.doi.org/10.1139/t99-038>
- Phoon, K., Kulhawy, F. H. and Grigoriu, M. D. (2003a). "Development of a Reliability-Based Design Framework for Transmission Line Structure Foundations." *Journal of Geotechnical and Geoenvironmental Engineering*, **129(9)**: 798-806. [http://dx.doi.org/10.1061/\(ASCE\)1090-0241\(2003\)129:9\(798\)](http://dx.doi.org/10.1061/(ASCE)1090-0241(2003)129:9(798))
- Phoon, K., Kulhawy, F. H. and Grigoriu, M. D. (2003b). "Multiple Resistance Factor Design for Shallow Transmission Line Structure Foundations." *Journal of Geotechnical and Geoenvironmental Engineering*, **129(9)**: 807-818. [http://dx.doi.org/10.1061/\(ASCE\)1090-0241\(2003\)129:9\(807\)](http://dx.doi.org/10.1061/(ASCE)1090-0241(2003)129:9(807))
- Polshin, D. E. and Tokar, R. A. (1957). "Maximum, Allowable Non-Uniform Settlement of Structures." *Proceedings of the Fourth International Conference on Soil Mechanics and*

Foundation Engineering: London 12-24 August 1957, vol. 1, Butterworths Scientific Publishing, London, United Kingdom, 402-405.

Poulos, H. G., Carter, J. P. and Small, J. C. (2001). "Foundations and retaining structures – research and practice." *Proceedings of the Fifteenth International Conference on Soil Mechanics and Geotechnical Engineering: Istanbul 27-31 August 2001*, vol. 4, A. A. Balkema, Lisse, Netherlands, 2527-2606.

Schneider, H. R. (1999). "Panel discussion: Definition and determination of characteristic soil properties." *Proceedings of the Fourteenth International Conference on Soil Mechanics and Geotechnical Engineering: Hamburg 6-12 September 1997*, vol. 4, A.A. Balkema, Rotterdam, Netherlands, 2271-2274.

Schwamb, T., Soga, K., Mair, R. J., Elshafie, M. Z. E. B., Sutherden, R., Boquet, C. and Greenwood, J. (2014). "Fibre Optic Monitoring of a deep circular excavation." *Proceedings of the Institution of Civil Engineers – Geotechnical Engineering*, **167(2)**: 144-154. <http://dx.doi.org/10.1680/geng.13.00036>

Schweiger, H. F., Thurner, R. and Pöttler, R. (2001). "Reliability Analysis in Geotechnics with Deterministic Finite Elements: Theoretical Concepts and Practical Application." *International Journal of Geomechanics*, **1(4)**: 389-413. [http://dx.doi.org/10.1061/\(ASCE\)1532-3641\(2001\)1:4\(389\)](http://dx.doi.org/10.1061/(ASCE)1532-3641(2001)1:4(389))

Scott, B., Kim, B. J. and Salgado, R. (2003). "Assessment of Current Load Factors for Use in Geotechnical Load and Resistance Factor Design." *Journal of Geotechnical and Geoenvironmental Engineering*, **129(4)**: 287-295. [http://dx.doi.org/10.1061/\(ASCE\)1090-0241\(2003\)129:4\(287\)](http://dx.doi.org/10.1061/(ASCE)1090-0241(2003)129:4(287))

Simpson, B. (2000). "Partial factors: where to apply them?" *LSD2000: International Workshop on Limit State Design in Geotechnical Engineering*, Melbourne, Australia, 18 November 2000 < <http://www.finzi-ceas.it/ceas/Docs/melbourne.pdf> > (Sept. 10, 2015)

- Simpson, B., Pappin, J. W. and Croft, D. D. (1981). "An approach to limit state calculations in geotechnics." *Ground Engineering*, **14(6)**: 21-26, 28.
- Skempton, A. W. and MacDonald, D. H. (1956). "Allowable settlement of buildings." *ICE Proceedings: Engineering Divisions*, **5(6)**: 727-768.
<http://dx.doi.org/10.1680/ipeds.1956.12202>
- Stokoe, K. H., Zalachoris, G., Cox, B. and Park, K. (2011). "Field evaluations of the effects of stress state, strain amplitude and pore pressure generation of shear moduli of geotechnical and MSW materials." *Proceedings of the Fifth International Symposium on Deformation Characteristics of Geomaterials, IS Seoul, 1-3 September 2011, Seoul, Korea*, Chung, C-K., Jung, Y-H., Kim, H-K., Lee, J-S. and Kim, D-S. (eds.), Vol. 1, IOS Press, Amsterdam, Netherlands, 120-140. <http://dx.doi.org/10.3233/978-1-60750-822-9-120>
- Terracina, F. (1962). "Foundations of the tower of Pisa." *Géotechnique*, **12(4)**: 336-339.
<http://dx.doi.org/10.1680/geot.1962.12.4.336>
- Terzaghi, K. and Peck, R. B. (1948). *Soil mechanics in engineering practice*. John Wiley & Sons, New York.
- TRB (2015). *Bridges for Service Life Beyond 100 Years: Service Limit Design*, SHRP 2 Report S2-R19B-RW-1, Transportation Research Board, Washington, D. C.,
< <http://onlinepubs.trb.org/onlinepubs/shrp2/SHRP2prepubR19B.pdf> > (Sept. 10, 2015).
- U.S. Department of the Interior Teton Dam Failure Review Group (1977). "Failure of Teton Dam: A Report of Findings." U.S. Government Printing Office, Washington, D.C.
- Vanmarcke, E. H. (1977). "Probabilistic modelling of soil profiles." *Journal of Geotechnical Engineering*, **103(11)**: 1227-1246.
- Vardanega, P. J., Lau, B. H., Lam, S. Y., Haigh, S. K., Madabhushi, S. P. G. and Bolton, M. D., Mayne, P. W. (2013a). "Discussion: Laboratory measurement of strength

mobilisation in kaolin: link to stress history.” *Géotechnique Letters*, **3(1)**: 16-17,

<http://dx.doi.org/10.1680/geolett.13.00005>

Vardanega, P. J., Kolody, E., Pennington, S. H., Morrison, P. R. J. and Simpson, B., N.

O’Riordan, N. and Kluzniak, B (2014). “Discussion: Bored pile design in stiff clay I: codes of practice.” *Proceedings of the Institution of Civil Engineers – Geotechnical*

Engineering, **167(1)**: 87-88, <http://dx.doi.org/10.1680/geng.13.00063>

Vardanega, P. J. and Bolton, M. D. (2011). “Strength mobilization in clays and silts.”

Canadian Geotechnical Journal, **48(10)**: 1485-1503. <http://dx.doi.org/10.1139/T11-052>

Vardanega, P. J. and Bolton, M. D. (2012). “Corrigendum: Strength mobilization in clays and

silts.” *Canadian Geotechnical Journal*, **49(5)**: 631. <http://dx.doi.org/10.1139/t2012-023>

Vardanega, P. J. and Bolton, M. D. (2013). “Stiffness of Clays and Silts: Normalizing Shear

Modulus and Shear Strain.” *Journal of Geotechnical and Geoenvironmental Engineering*,

139(9): 1575-1589. [http://dx.doi.org/10.1061/\(ASCE\)GT.1943-5606.0000887](http://dx.doi.org/10.1061/(ASCE)GT.1943-5606.0000887)

Vardanega, P. J. and Bolton, M. D. (2014). “Stiffness of Clays and Silts: Modeling

Considerations.” *Journal of Geotechnical and Geoenvironmental Engineering*, **140(6)**:

06014004. [http://dx.doi.org/10.1061/\(ASCE\)GT.1943-5606.0001104](http://dx.doi.org/10.1061/(ASCE)GT.1943-5606.0001104)

Vardanega, P. J., Kolody, E., Pennington, S. H., Morrison, P. R. J. and Simpson, B. (2012a).

“Bored pile design in stiff clay I: codes of practice.” *Proceedings of the Institution of Civil Engineers – Geotechnical Engineering*, **165(4)**: 213-232,

<http://dx.doi.org/10.1680/geng.11.00062>

Vardanega, P. J., Lau, B. H., Lam, S. Y., Haigh, S. K., Madabhushi, S. P. G. and Bolton,

M. D. (2012b). “Laboratory measurement of strength mobilization in kaolin: link to stress history.” *Géotechnique Letters*, **2(1)**: 9-15, <http://dx.doi.org/10.1680/geolett.12.00003>

- Vardanega, P. J., Williamson, M. and Bolton, M. D. (2012c). “Bored pile design in stiff clay II: mechanisms and uncertainty.” *Proceedings of the Institution of Civil Engineers – Geotechnical Engineering*, **165(4)**: 233-246, <http://dx.doi.org/10.1680/geng.11.00063>
- Vardanega, P. J., Williamson, M. and Bolton, M. D. (2013b). “Corrigendum: Bored pile design in stiff clay II: mechanisms and uncertainty.” *Proceedings of the Institution of Civil Engineers – Geotechnical Engineering*, **166(5)**: 518-518, <http://dx.doi.org/10.1680/geng.2013.166.5.518>
- Whitman, R. V. (2000). “Organising and evaluating uncertainty in geotechnical engineering.” *Journal of Geotechnical and Geoenvironmental Engineering*, **126(7)**: 583-593. [http://dx.doi.org/10.1061/\(ASCE\)1090-0241\(2000\)126:7\(583\)](http://dx.doi.org/10.1061/(ASCE)1090-0241(2000)126:7(583))
- Zhang, D. M., Phoon, K. K., Huang H. W. and Fu, Q. F. (2015). “Characterisation of Model Uncertainty for Cantilever Deflections in Undrained Clay.” *Journal of Geotechnical and Geoenvironmental Engineering*, **141(1)**: 04014088. [http://dx.doi.org/10.1061/\(ASCE\)GT.1943-5606.0001205](http://dx.doi.org/10.1061/(ASCE)GT.1943-5606.0001205)
- Zhang, J., Andrus, R. D., and Juang, C. H. (2005). “Normalised shear modulus and material damping ratio relationships.” *Journal of Geotechnical and Geoenvironmental Engineering*, **131(4)**: 453-464. [http://dx.doi.org/10.1061/\(ASCE\)1090-0241\(2005\)131:4\(453\)](http://dx.doi.org/10.1061/(ASCE)1090-0241(2005)131:4(453))
- Zhang, L., Tang, W. H. and Ng, C. W. W. (2001). “Reliability of Axially Loaded Driven Piles Groups.” *Journal of Geotechnical and Geoenvironmental Engineering*, **127(12)**: 1051-1060. [http://dx.doi.org/10.1061/\(ASCE\)1090-0241\(2001\)127:12\(1051\)](http://dx.doi.org/10.1061/(ASCE)1090-0241(2001)127:12(1051))

Table 1: Suggested Limits for the Relative Deflection of Structures

Type of Structure	Limit state	Sources	Magnitude	Guideline
			$\Delta w/L \equiv 0.5\beta$	$\Delta w/L$
Framed buildings	Hazard (dangerous cracking)	P&	1/300 to 1/500	1/300
		Bo	1/300	
		Bu&	1/600	
	Serviceability (severe cracking)	P&	1/1000 to 1/2000	1/600
Bo		1/600	to	
	Bu&	1/1200	1/1200	
	Appearance (repairable cracking)	Bo	1/2400	1/2400
	Machinery (malfunction)	P&	1/2400 to 1/4000	1/2400
Load-bearing Walls	Hazard	Bo	1/300	1/300
		Bu&		
	Serviceability	Bo	1/600	1/600
Bu&		1/2000 sag	to	
	Bu&	1/2000 hog	1/1200	
Appearance	Appearance	Bo	1/1200	1/1200 sag to 1/2400 hog
		Bu& sag	1/2000	
		P& sag	1/1250 to 1/2500	
		P& hog	1/2500 to 1/5000	
Bridges	Structural damage	P&	1/500	1/500
	Serviceability	TRB	1/250 to 1/500	1/500
P& = Poulos et al. (2001) Bo = Boscardin and Cording (1989) Bu& = Burland et al. (2004) and Burland et al. (1977) TRB = TRB (2015)				

Table 2: Types of Geotechnical Uncertainty (Adapted from McMahon 1985, with Permission from the Australian Geomechanics Society)

Type	Description	Cause of Uncertainty
1	Risk of encountering an unknown geological condition	Technical
2	Risk of using the wrong geotechnical criteria e.g., designing to the wrong failure mechanism or failure to anticipate the eventual failure mechanism	Technical
3	The risk of bias and/or variation in the design parameters being greater than estimated	Technical
4	Human error	Social
5	Design changes	Social
6	Over conservatism	Social

Table 3: Some Classical Factors of Safety for Geotechnical Practice (Data from Terzaghi and Peck 1948)

Type of Construction	Quoted Factor of Safety (FOS) value	T&P Article
<u>Retaining Structures</u>	1.5 (against sliding) 1.5 (base heave) 2.0 (strut buckling)	Art. 46 Art. 32 Art. 48
<u>Slope stability</u>	1.3-1.5	Art. 51
<u>Embankments</u>	1.5 1.1-1.2 with monitoring	Art. 52
<u>Foundations</u>		
Footings and rafts	2-3	Art. 53 to 55
Single piles	2.5-3 (with load testing) 6 (with 'Engineering News' formula)	Art. 56
Floating pile groups	2-3 (w. r. t. base failure)	

Table 4: Comparison of different partial factor sets from different historical codes of practice (Adapted from Meyerhof 1995) [Original source: Meyerhof, G. G. (1995). Development of Geotechnical Limit State Design. *Canadian Geotechnical Journal*, 32(1): 128-136 © Canadian Science Publishing or its licensors]

Item	Brinch Hansen		Denmark DS 415	Eurocode 7	Canada CFEM	Canada NBCC	USA ANSI A58
	(1953)	(1956)	(1965)	(1993)	(1992)	(1995)	(1980)
Loads							
Dead Loads, soil weight	1.0	1.0	1.0	1.1 (0.9)	1.25 (0.8)	1.25 (0.85)	1.2 – 1.4 (0.9)
Live Loads	1.5	1.5	1.5	1.5 (0)	1.5 (0)	1.5 (0)	0.5 – 1.6 (0)
Environmental Loads	1.5	1.5	1.5	1.5 (0)	1.5 (0)	1.5 (0)	1.3 – 1.6 (0)
Water pressures	1.0	1.0	1.0	1.0 (1.0)	1.25 (0.8)	1.25 (0)	
Accidental loads		1.0	1.0	1.0 (0)			
Shear strength							
Friction ($\tan\phi$)	1.25	1.2	1.25	1.25	1.25	Resistance factor of 1.25 – 2.0 on ultimate resistance using unfactored strengths	Resistance factor of 1.2– 1.5 on ultimate resistance using unfactored strengths
Cohesion (c) (slopes, earth pressures)	1.5	1.5	1.5	1.4 – 1.6	1.5		
Cohesion (c) (spread foundations)		1.7	1.75	1.4 – 1.6	2.0		
Piles		2.0	2.0	1.4 – 1.6	2.0		
Ultimate Pile Capacities							
Load tests		1.6	1.6	1.7 – 2.4	1.6 – 2.0	1.6	
Dynamic formulas		2.0	2.0		2.0	2.0	
Penetration tests					2.0 – 3.0	2.5	
Deformations							
		1.0	1.0	1.0	1.0	1.0	1.0
N.B. Load factors in parentheses apply to dead and live loads when their effect is beneficial							

Table 5: Statistical Variation of b , $\gamma_{M=2}$ and α and γ_{ref} for Clays Included in the Databases of Vardanega and Bolton (Data from Vardanega and Bolton 2011, 2013)

Statistic	Moderate Strain		Small Strain			
			Static		Dynamic	
	b	$\gamma_{M=2}$	α	γ_{ref}	α	γ_{ref}
Maximum	1.21	0.044	1.13	0.0034	2.16	0.0050
Minimum	0.32	0.0015	0.50	0.00024	0.69	0.00037
Mean, μ	0.60	0.0088	0.75	0.00097	1.05	0.0017
Standard Deviation, σ	0.15	0.068	0.12	0.00071	0.25	0.0012
COV = σ/μ	0.25	0.78	0.16	0.73	0.23	0.70

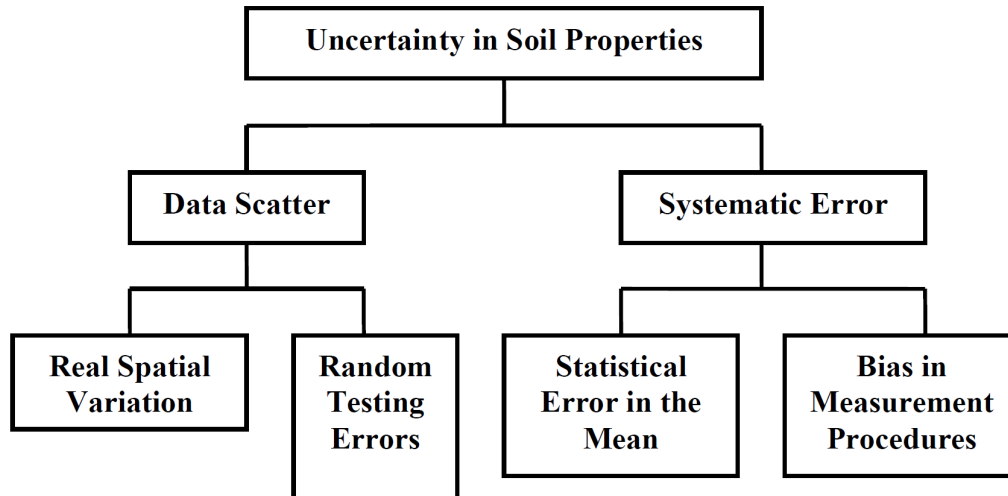

Figure 1: Categories of uncertainty in soil properties (adapted from Christian et al.

1994 © ASCE).

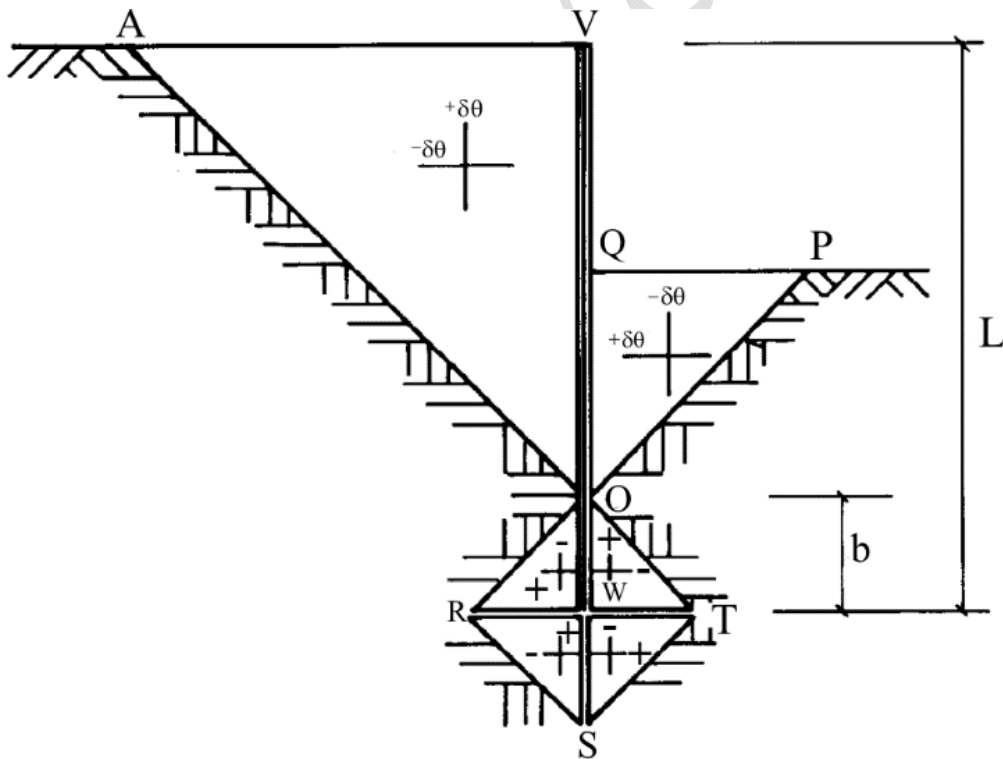

Figure 2: Admissible strain field for embedded cantilever wall rotating about a point just above its base: Rigid wall (adapted from Bolton and Powrie 1988, with permission

from ICE Publishing).

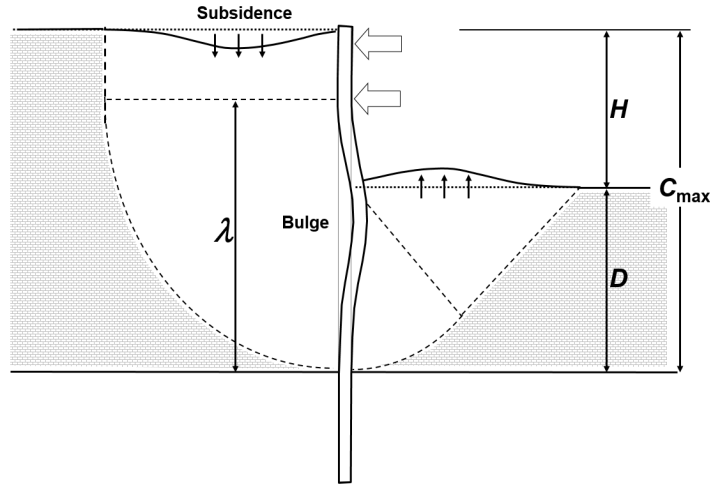

Figure 3: MSD lateral bulging mechanism (adapted from Bolton et al. 2014, Reprinted by Permission from Higher Education Press Limited Company: Frontiers of Structural and Civil Engineering, Vol. 8, No. 3, page 204, copyright 2014)

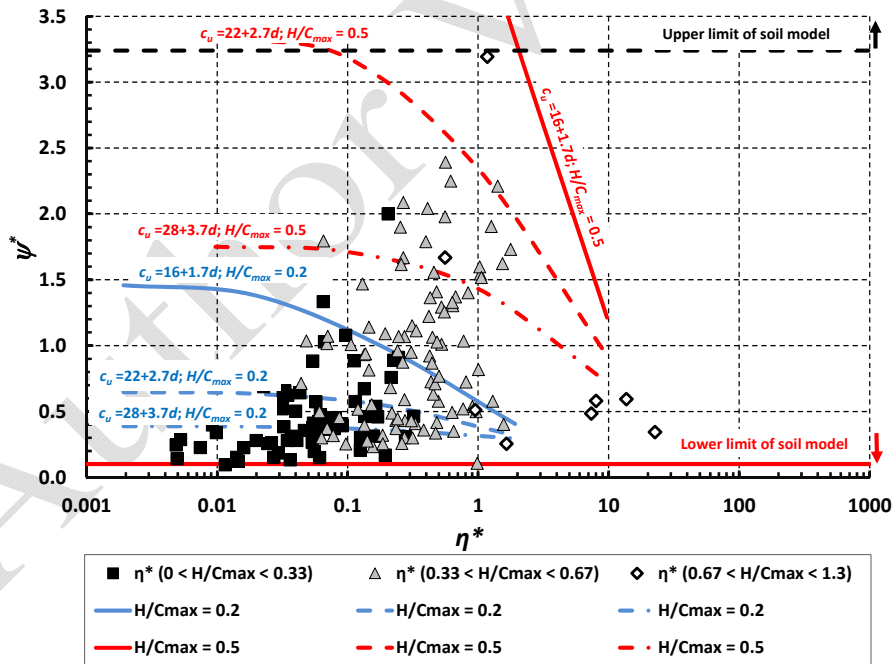

Figure 4: MSD design lines compared with database of excavations in Shanghai (adapted from Bolton et al. 2014, Reprinted by Permission from Higher Education Press Limited Company: Frontiers of Structural and Civil Engineering, Vol. 8, No. 3, page 218, copyright 2014)