



Karboyan, S., Uren, M. J., Martin Horcajo, S., Pomeroy, J. W., Chatterjee, I., Moens, P., Banerjee, A., Caesar, M., & Kuball, M. (2016). Dynamic-Ron in Small and Large C-doped AlGaN/GaN-on-Si HEMTs. In *CS MANTECH 2016: International Conference on Compound Semiconductor Manufacturing Technology* (pp. 211-214). CS Mantech. <http://csmantech2016.conferencespot.org/62266gmi-1.3079367/t012-1.3079845/f012-1.3079847/a047-1.3079853/an047-1.3092027>

Peer reviewed version

[Link to publication record in Explore Bristol Research](#)  
PDF-document

This is the author accepted manuscript (AAM). The final published version (version of record) is available online via CS MANTECH at <http://csmantech2016.conferencespot.org/62266gmi-1.3079367/t012-1.3079845/f012-1.3079847/a047-1.3079853/an047-1.3092027>. Please refer to any applicable terms of use of the publisher.

## University of Bristol - Explore Bristol Research

### General rights

This document is made available in accordance with publisher policies. Please cite only the published version using the reference above. Full terms of use are available: <http://www.bristol.ac.uk/red/research-policy/pure/user-guides/ebr-terms/>

# Dynamic-Ron in Small and Large C-doped AlGa<sub>N</sub>/Ga<sub>N</sub>-on-Si HEMTs

S. Karboyan<sup>1</sup>, M. J. Uren<sup>1</sup>, S. Martin Horcajo<sup>1</sup>, J. W. Pomeroy<sup>1</sup>, I. Chatterjee<sup>1</sup>, P. Moens<sup>2</sup>, A. Banerjee<sup>2</sup>  
M. Caesar<sup>2</sup>, M. Kuball<sup>1</sup>

<sup>1</sup>H H Wills Physics Laboratory, University of Bristol, BS8 1TL, United Kingdom

<sup>2</sup>ON Semiconductor, Oudenaarde 9700, Belgium

Corresponding author: [serge.karboyan@bristol.ac.uk](mailto:serge.karboyan@bristol.ac.uk)

**Keywords:** HEMT, GaN, AlGa<sub>N</sub>, Power devices, Dynamic on Resistance, device size.

## Abstract

We report that dynamic Ron can increase with off-state stress time, only saturating after >300s. We show that a wide range of dynamic Ron behaviors is observed in small devices whereas large devices show behavior characteristic of an average over the small devices. This behavior can be explained by preferential vertical leakage paths separated by tens of microns. Long time constant dispersion is observed in some wafers but this is suppressed in later generation epitaxy.

## INTRODUCTION

GaN power devices show tremendous promise for high efficiency, high voltage switching applications due to the high breakdown field and low on-state resistance which result from basic material advantages. To achieve this performance requires that the device has low off-state leakage combined with high operating voltage, fabricated on a low-cost manufacturable platform. Here we report on MISHEMT devices fabricated using a GaN-on-Si process delivering high performance 650V switches [1-2]. The increase of the on-resistance of the channel in AlGa<sub>N</sub>/Ga<sub>N</sub> HEMTs following off-state stress is a critical issue and needs to be minimized. In particular the introduction of carbon in the GaN buffer to increase the breakdown voltage is found to impact the channel conduction mechanisms causing an increase in the on-resistance under different transient conditions [3-4, 7].

This paper demonstrates that dynamic on-resistance can increase with stress time, only saturating after greater than 300s. This observation has significant importance for the measurement of dynamic Ron since most reported measurements only use stress times much less than 1s. We show for the first time that significant differences in dynamic on-resistance behavior can exist between small and large devices from the same wafer associated with widely spaced preferential leakage paths. We also show that large variations can exist between epitaxies, with more recent wafers showing reduced dispersion and long time constant dynamic Ron recovery behavior.

## EXPERIMENTS AND DEVICES UNDER TEST

Carbon-doped AlGa<sub>N</sub>/Ga<sub>N</sub>-on-Si MISHEMTs fabricated using the process described in [1, 8-9] are studied. Two wafers (A and B) of different epitaxial generations are considered here. The pinch-off voltage is -8V and the devices are biased in the off-state with  $V_{GS} = -10V$  and  $V_{DSoff-stress} = 100V$  for a time period of up to 1000s before switching to the on-state with  $V_{GS} = 0V$  and  $V_{DS} = 1V$ . The on-state resistance Ron was then recorded for at least 1000s. This corresponds to a “worst case”  $V_{DS}$  for dynamic Ron measurement [2, 10] as shown in Fig. 1. For the purpose of this study, 2 types of devices are tested denoted small and large devices. The ratio of the isolated area of the small single gate finger ( $W_G = 200\mu m$ ) and large multifinger power transistors is 1/630. In this paper, we used the same approach of the measurement of the dynamic on-resistance explained by Joh et al. in [6].

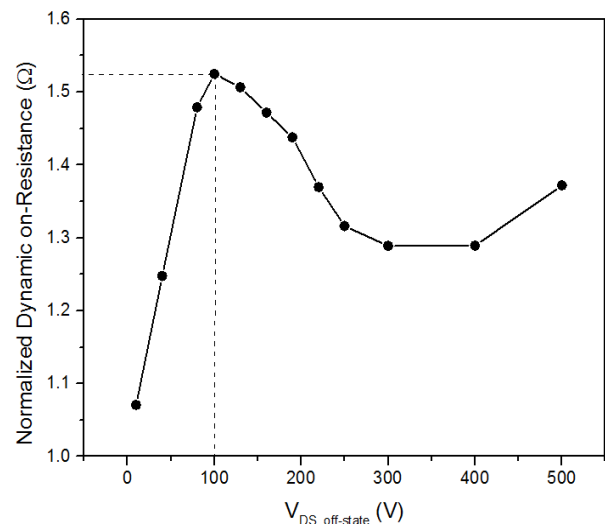
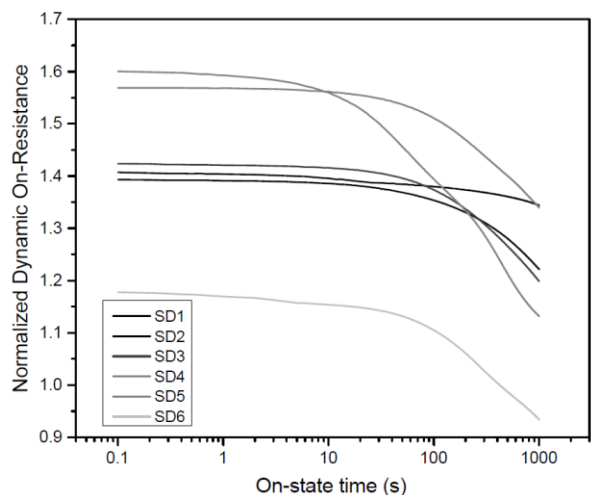

Fig. 1. Normalized dynamic on-resistance magnitude for a C-doped AlGa<sub>N</sub>/Ga<sub>N</sub> device 1s after turn-on following 1000s at the indicated off-state voltage.

## RESULTS

Fig. 2 shows for wafer A the normalized dynamic Ron measurements relative to the static value for each device before stress, at room temperature (RT) and 80°C. The measurements are carried out after switching from off-state to on-state. Considering first the large devices shown in Fig. 2(b) and 2(d) we can see that the measurement time spanned a range of 4 decades but this was insufficient to observe full recovery at room temperature after 1000s. However, when comparing measurements collected at RT and 80°C, the data suggests that the broad distribution of time constants actually extend over about 6 decades in time for all the tested devices. By contrast, the small devices in Fig. 2(a) and 2(c) show a small number of discrete time-constant responses that are different in each device but with time constants distributed over the same 6 decades, indicating that the large device behavior is a superposition of multiple small devices. Moreover, when comparing small and large

devices, we notice that the variation in resistance after 0.1s in on-state is much larger on the small devices (20-65%) in comparison to the large devices (10-40%). Fig. 3 shows the result of dynamic Ron measurements on small and large devices on wafer B. It is found that there is again a variation between devices, but with most small devices showing no significant dynamic Ron dispersion, and none showing the very long recovery time seen in wafer A; indicating that the long time constant dispersion observed in wafer A is suppressed in wafer B. Added to this, the variation observed between small and large devices from wafer B after 0.1s in on-state is 10-20% for both types of device. Figs. 4 shows how the magnitude of the dynamic Ron increases with off-state stress time for wafers A and B, in both cases saturating at long times. The trapping process seen in Fig. 4 does not show the very wide time constant dispersion observed in Fig. 2. The magnitude of the worst-case dynamic Ron is significantly lower for wafer B than wafer A (15% compared to 40-50% at saturation).



(a) Small devices at RT

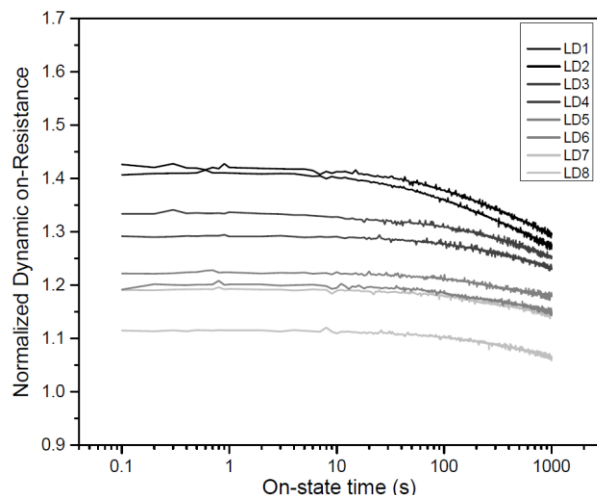

(b) Large devices at RT

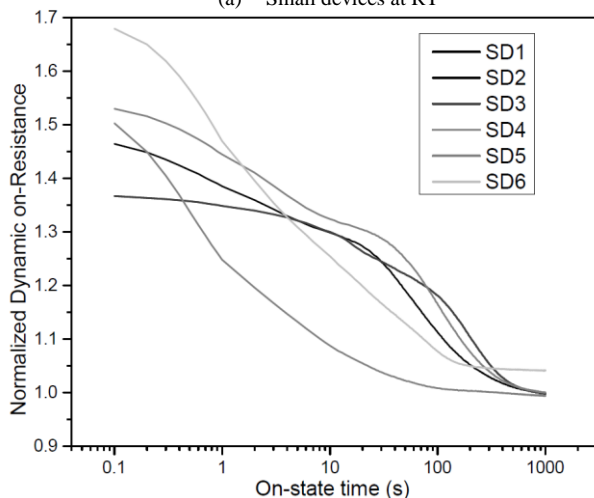

(c) Small devices at 80°C

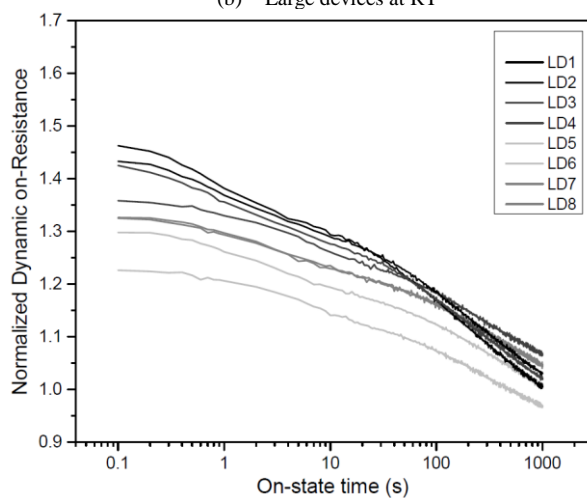

(d) Large devices at 80°C

Fig. 2. Wafer A: Measured Dyn-Ron transients after switching from off-state ( $V_{GS} = -10V$ ,  $V_{DS} = 100V$ ) to on-state ( $V_{GS} = 0$ ,  $V_{DS} = 1V$ ) on different small (SD) and large (LD) devices at RT and 80°C. The measurements are normalized relative to the DC value of the on-resistance before off-state stress.

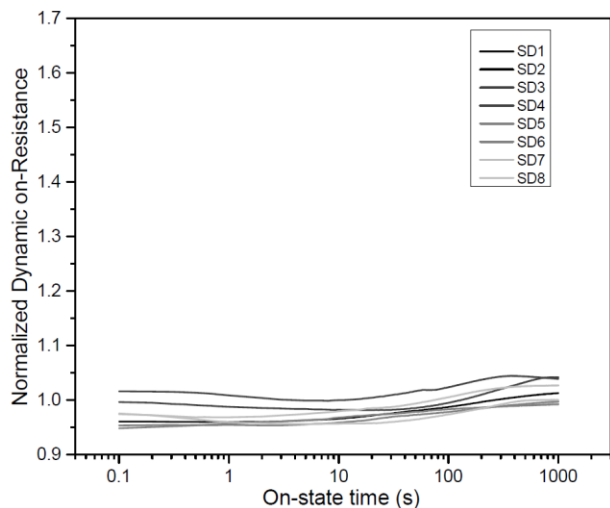

(a) Small devices at RT

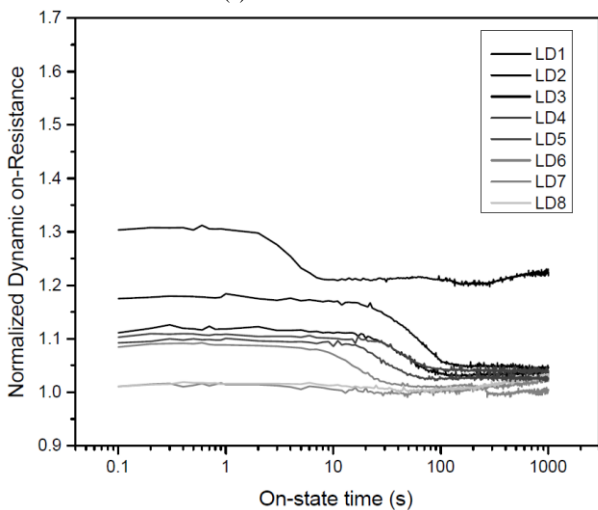

(b) Large devices at RT

Fig. 3. Wafer B: Measured Dyn-Ron transients at RT under the same conditions as in Fig. 2.

## Discussions

Let us first consider the situation in Wafer A. It is normally assumed that dynamic  $R_{on}$  is solely associated with trapping in point defects which are uniformly distributed within each epitaxial layer. However the difference between large and small devices indicates that dynamic  $R_{on}$  recovery time can vary across the wafer with a length scale of less than hundred microns. The dynamic  $R_{on}$  recovery transient in a small device is due a small number of discrete trapping responses having a wide distribution of recovery time constants. The behavior of large devices is then a superposition of that distribution of time constants seen in the small devices. This suggests that the trapping process involves transport along localized defects which are separated by many 10's of microns. We propose that the variation in  $R_{on}$  recovery time is a result of leakage along a

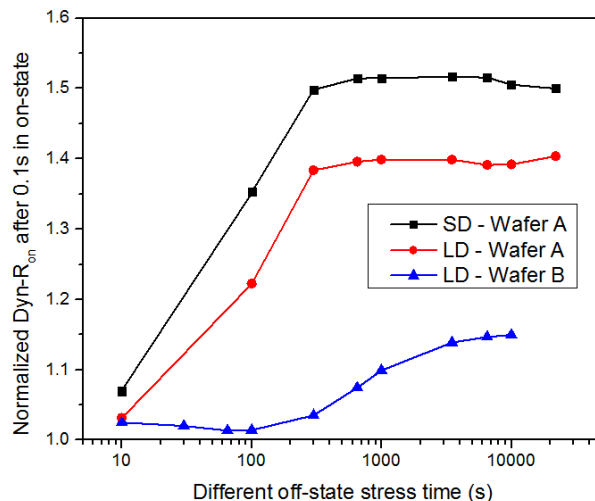

Fig. 4. Normalized Dyn-Ron at 40°C, 0.1s after switching to on-state for small (SD) and large (LD) devices from wafers A and B.

tiny fraction of the high density of threading dislocations, perhaps those with high screw component as is observed in the case of reverse biased GaN LEDs [11]. Fig 5 shows schematically the transport process that would be involved in the recovery transient when there is a single extended-defect leakage path. The negative (and small positive) trapped charge responsible for the dynamic  $R_{on}$  and stored during the off-state drain stress step is shown in its location in the gate-drain gap [2,10]. The recovery transient then requires a source of holes to flow within the weakly p-type carbon doped GaN layer [5] to neutralize these charges. In the figure the vertical leakage path that provides a route for those holes to flow from the contacts is placed under the drain and is connected to the 2DEG, however it could be located anywhere and also could be connected to the Si. The important point is that there will be a variation in the lateral transport distance within the highly resistive GaN:C between the location of the trapped negative charge and the leakage path. This could result in the wide range of time constants which is observed.

By contrast the trapping process during the drain stress is not dependent on device size, and does not show the strong dispersion in time constant seen in the recovery process. This can be straightforwardly explained by noting that the fields during off-state stress are much higher than during the on-state recovery, and given that vertical leakage paths are highly non-ohmic, leakage can occur over the entire device area, resulting in the reduced time constant dispersion observed.

By contrast, wafer B shows much less variability and less trapping, indicating that improved control of the epitaxy has reduced the voltage drops in the GaN:C layer driving the off-state trapping process, and improved the uniformity of the leakage paths responsible for the recovery process following switching to the on-state.

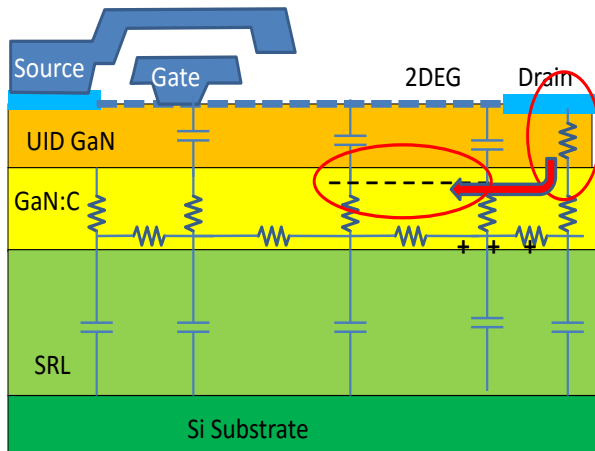

Fig. 5. Schematic representation of the hole transport path during the on-state recovery transient. The negative ionized carbon acceptor charge exposed during the off-state stress is circled, as is the single extended-defect leakage path which allows holes to flow from the contacts.

## CONCLUSIONS

This study shows that there is a fundamental asymmetry in the trapping and de-trapping process involved in dynamic Ron dispersion. We have shown that the time constants for dispersion are not just set by the trap energy level and cross-section, but in this case more importantly by the transport path to the trap. We have found that in some wafers dynamic Ron is dominated by lateral transport from a low density of leakage paths separated by many tens of microns. Good control of the epitaxy can suppress this issue. This study indicates that it is important to consider device size as well as stress-time in any study of dynamic Ron dispersion.

## ACKNOWLEDGEMENTS

This work was supported by the UK EPSRC “PowerGaN” project EP/K011447/1 and the ENIAC E2COGaN project.

## REFERENCES

- [1] P. Moens, C. Liu, A. Banerjee, P. Vanmeerbeck, H. Ziad et al., “An Industrial Process for 650V rated GaN-on-Si Power Devices using in-situ SiN as a Gate Dielectric”, *Proc. of ISPSD*, 2014.
- [2] P. Moens, A. Banerjee, M. J. Uren, M. Meneghini, S. Karboyan, I. Chatterjee et al. “Impact of buffer leakage on intrinsic reliability of 650V AlGaIn/GaN HEMTs”, *IEDM*, 2015.
- [3] E. B. Treidel, F. Brunner, O. Hilt, E. Cho, J. Wurfl and G. Trankle, “AlGaIn/GaN/GaN:C Back-Barrier HFETs With Breakdown Voltage of Over 1 kV and Low  $RON \times A$ ”, *IEEE Trans. on Elec. Devices*, Vol. 57, No. 11, 2010.

- [4] D. Bisi, M. Meneghini, F. Alessio Marino, D. Marcon, S. Stoffels et al., “Kinetics of Buffer-Related Ron increase in GaN-on-Si MIS-HEMTs”, *IEEE Elec. Dev. Letters*, Vol. 35, No. 10, 2014.
- [5] M. J. Uren, M. Silvestri, M. Cäsar, G. A. M. Hurkx, J. A. Croon, J. Šonský, and M. Kuball, “Intentionally Carbon-Doped AlGaIn/GaN HEMTs: The Necessity for Vertical Leakage Paths”, *IEEE Elec. Dev. Lett.*, vol. 35, pp. 327-329, 2014.
- [6] J. Joh and J. A. Del Alamo, “A Current-Transient Methodology for Trap Analysis for GaN High Electron Mobility Transistors”, *IEEE Trans on Elec. Devices*, Vol. 58, No. 1, 2011.
- [7] M. J. Uren, J. Moreke and M. Kuball, “Buffer Design to Minimize Current Collapse in GaN/AlGaIn HFETs”, *IEEE Trans. on Elec. Devices*, Vol. 59, No. 12, 2012.
- [8] P. Moens, P. Vanmeerbeck, A. Banerjee, J. Guo, C. Liu et al., “On the Impact of Carbon-Doping on the Dynamic Ron and Off-state Leakage Current of 650V GaN Power Devices”, *Proc. of ISPSD*, 2015.
- [9] C. Liu, A. Salih, B. Padmanabhan, W. Jeon, P. Moens, M. Tack and E. De Backer, “Breakthroughs for 650-V GaN Power Devices: Stable high-temperature operations and avalanche capability”, *IEEE Power Electronics Magazine*, pp. 44-50, September 2015.
- [10] M. J. Uren, M. Caesar, S. Karboyan, P. Moens, P. Vanmeerbeck and M. Kuball, “Electric Field Reduction in C-doped Algan/GaN on Si HEMTs”, *IEEE Elec. Dev. Letters*, Vol. 36, No. 8, 2015.
- [11] D. S. Li, H. Chen, H. B. Yu, H. Q. Jia, Q. Huang, and J. M. Zhou, “Dependence of leakage current on dislocations in GaN-based light-emitting diodes,” *J. Appl. Phys.*, vol. 96, pp. 1111-1114, Jul 2004.
- [12] M. J. Uren, M. Cäsar, M. A. Gajda, and M. Kuball, “Buffer Transport Mechanisms in Intentionally Carbon Doped GaN Heterojunction Field Effect Transistors”, *Appl. Phys. Lett.*, vol. 104, p. 263505, 2014.

## ACRONYMS

- HEMT: High Electron Mobility Transistor
- MISHEMT: Metal Insulated Semiconductor HEMT
- SD: Small Devices
- LD: Large Devices
- AlGaIn: Aluminium Gallium Nitride.
- Dyn-Ron: Dynamic On-Resistance

